Educational Services



**KFQSA Module
Installation and User Manual**

EK-KFQSA-IN-003

Digital Equipment Corporation

March 1992

The information in this document is subject to change without notice and should not be construed as a commitment by Digital Equipment Corporation. Digital Equipment Corporation assumes no responsibility for any errors that may appear in this document.

Copyright © Digital Equipment Corporation 1992

All Rights Reserved.
Printed in U.S.A.

The following are trademarks of Digital Equipment Corporation: Digital, DEQNA, DSSI, HSC, KDA, MicroVAX, MicroVAX II, MS630, MSCP, Q-bus, Q22-bus, RA, RQC25, RQDX3, RRD50, STI, TK, TMSCP, TQK, TQK50, ULTRIX-32m, UNIBUS, VAX, VAXcluster, VAXELN, VMS, and the DIGITAL logo.

LEGAL NOTICE: TMSCP and STI protocols and documentation are proprietary information of Digital Equipment Corporation. UNIBUS and Q-bus port drivers and documentation of MSCP and TMSCP products are also proprietary information of Digital Equipment Corporation.

Contents

About This Manual	vii
1 General Information	
1.1 KFQSA Module Overview	1-1
1.2 BA440 System Enclosure	1-5
1.3 BA213 System Enclosure	1-7
1.4 BA123 System Enclosure	1-10
1.5 BA23 System Enclosure	1-12
1.6 DSSI VAXcluster Configurations	1-14
2 Unpacking Instructions	
2.1 Option Kits	2-1
2.2 Inspection	2-3
3 Planning the System Installation	
4 KFQSA Switches	
5 Installation Procedures	
5.1 BA440 Installation Procedure Using the KFQSA-SG Option Kit	5-2
5.2 BA213 Installation Procedure Using the KFQSA-SG Option Kit	5-6
5.3 BA123 Installation Procedure Using the KFQSA-BA Option Kit	5-9
5.4 BA23 Installation Procedure Using the KFQSA-AA Option Kit	5-14
5.5 Installing DSSI VAXcluster Configurations	5-17
5.5.1 Types of DSSI Bus Configurations	5-17
5.6 Rules for Installing DSSI VAXcluster Systems	5-18

6	Programming the DSSI Subsystem Using Console Commands	
6.1	Determining CSR Addresses	6-1
6.2	Programming the KFQSA Configuration Table	6-3
6.3	Programming the KFQSA Module for a DSSI VAXcluster Configuration	6-7
6.4	Setting the ISE Allocation Class	6-11
7	Configuring the DSSI Subsystem Using MDM Commands	
7.1	Determining CSR Addresses	7-1
7.1.1	Overview	7-1
7.1.2	Using MDM to Determine CSR Addresses	7-2
7.2	Programming the KFQSA Configuration Table	7-4
7.2.1	Programming a Blank or Unknown Configuration Table ..	7-4
7.2.2	Adding a Device to the Configuration Table	7-10
7.2.3	Removing a Device from the Configuration Table	7-13
7.3	Programming the KFQSA for a DSSI VAXcluster Configuration	7-15
7.4	Setting the ISE Allocation Class	7-17
8	Diagnostics	
8.1	Power-On Self-Test Diagnostics	8-1
8.2	LED Error Codes	8-2
8.3	Using MDM to Run NAKFA Diagnostics	8-5
8.3.1	Loading NAKFA	8-5
8.3.2	Testing the KFQSA Subsystem Using NAKFA in Menu Mode	8-8
8.3.3	Halting Test Execution	8-10
8.4	Using Console Commands for Testing DSSI Devices	8-11

9 KFQSA Troubleshooting

Index

Figures

1-1	DSSI Single Host Configuration	1-2
1-2	DSSI VAXcluster with Dual Hosts	1-3
1-3	DSSI VAXcluster with Three Hosts	1-4
1-4	BA440 Enclosure	1-5
1-5	BA440 Backplane	1-6
1-6	BA213 Enclosure	1-7
1-7	BA213 Backplane Bus Grant Continuity Path	1-9
1-8	BA123 Enclosure	1-10
1-9	BA123 Backplane Bus Grant Continuity Path	1-11
1-10	BA23 Enclosure	1-12
1-11	BA23 Backplane Bus Grant Continuity Path	1-13
1-12	Two-System DSSI VAXcluster Configuration	1-16
1-13	Three-System DSSI VAXcluster Configuration	1-17
1-14	DSSI VAXcluster with an Expansion Cabinet	1-17
2-1	KFQSA Jumper Location	2-3
3-1	BA440 Configuration Worksheet	3-2
3-2	BA213 Configuration Worksheet	3-3
3-3	BA123 Configuration Worksheet	3-4
3-4	BA23 Configuration Worksheet	3-5
4-1	KFQSA Adapter Module Switches	4-2
5-1	BA440 Cabling for a KFQSA in a VAX 4000 System	5-4
5-2	Installing the Gap Filler Assembly	5-5
5-3	Cabling for a KFQSA in a Host System Using a BA213 Enclosure	5-7
5-4	KFQSA Installation in a BA123 Enclosure	5-9
5-5	Removing the Right Side Panel	5-11
5-6	Removing the Card Cage Door	5-12
5-7	KFQSA Installation in a BA23 Enclosure	5-15
6-1	KFQSA Modules in a DSSI VAXcluster — Two-System Configuration	6-8

6-2	KFQSA Modules in a DSSI VAXcluster — Three-System Configuration	6-9
7-1	Two-System DSSI VAXcluster Configuration	7-16
8-1	KFQSA MODULE LEDS Location	8-2

Tables

2-1	KFQSA Option Kits	2-2
3-1	Power and Bus Load Data	3-6
4-1	KFQSA Switch Settings	4-3
4-2	Selecting a Dedicated KFQSA CSR Address	4-4
4-3	Selecting an MSCP or TMSCP CSR Address	4-4
7-1	Device Abbreviations Used with IOADDRESS	7-3
8-1	POST LED Nonfatal Error Codes	8-3
8-2	POST LED Fatal Error Codes	8-4
9-1	KFQSA Troubleshooting Symptom Analysis	9-2

About This Manual

This manual provides the information and procedures necessary to install a KFQSA module and DSSI cabling into a MicroVAX system in a BA440, BA213, BA123, or BA23 enclosure. It also provides instructions for configuring a system using the MicroVAX Diagnostic Monitor (MDM) or console commands, and for programming the Control and Status Register (CSR) addresses of the connected DSSI integrated storage elements.

Intended Audience

This document is intended to be used by Digital Services personnel or by qualified self-maintenance customers.

Customers not qualified to install the KFQSA module and the DSSI cabling should call Digital Services to schedule an installation.

For the Customer

The customer is responsible to back up software before the arrival of Digital Services personnel at the site. This step is important to ensure that data is not lost during the installation process.

CAUTION

Make sure you are wearing an antistatic wrist strap connected to a grounded antistatic workstation before you handle the module. The KFQSA module is susceptible to damage by static discharge.

To install the KFQSA adapter and DSSI cable, carefully follow the procedures outlined in this manual. If you have any difficulty performing the installation, call Digital Services for assistance.

Be sure the bus grant continuity path is intact after the installation. No vacant backplane slots should exist between modules.

For Digital Services

Be sure to take antistatic precautions when unpacking and installing the module. Use the groundstrap and antistatic mat found in the Antistatic Kit (PN 29-26246).

To install the KFQSA and DSSI cable, carefully follow the installation procedures outlined in this manual. When you have completed the installation, submit a labor activity reporting system (LARS) form. For information on completing this form, contact your unit manager.

General Information

This chapter describes the KFQSA module and the enclosures into which it can be installed.

1.1 KFQSA Module Overview

The KFQSA module is an adapter that allows Q-bus based host systems like the MicroVAX system to communicate with Integrated Storage Elements (ISEs) connected through the DSSI bus. ISEs are intelligent storage peripherals such as disk and tape devices. In a DSSI single host configuration, the KFQSA can connect up to seven ISEs to the host computer through the DSSI bus. In a DSSI VAXcluster configuration with a dual host configuration two KFQSAs can connect up to six ISEs to the two hosts through the DSSI bus. In a DSSI VAXcluster configuration with a three host configuration and three KFQSAs, the DSSI bus can connect up to five ISEs.

Each DSSI ISE has its own controller, which contains the intelligence and logic necessary to control data transfers over the DSSI bus. The KFQSA contains the addressing logic required to make a connection between the host and a requested ISE on the DSSI bus.

The KFQSA module is supported by the following operating systems and diagnostic utilities:

- VMS Version 5.1 or later¹
- ULTRIX-32m Version 3.0 or later
- VAXELN Version 3.0 or later
- NDM Version 3.0 or later

¹ KFQSA DSSI VAXcluster configurations must use VMS Version 5.1-1 or later.

1-2 General Information

Figure 1-1, Figure 1-2, and Figure 1-3 display some of the typical DSSI VAXcluster host configurations and KFQSAs to ISEs relationships.

Figure 1-1 DSSI Single Host Configuration

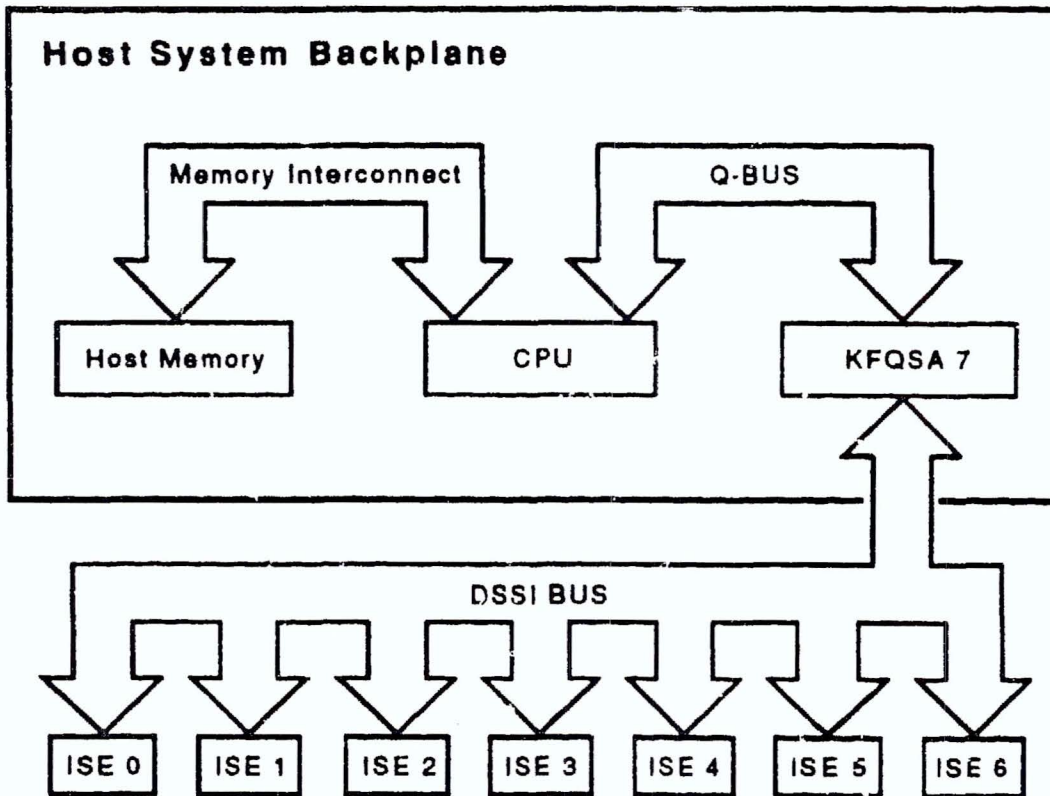

Figure 1-2 DSSI VAXcluster with Dual Hosts

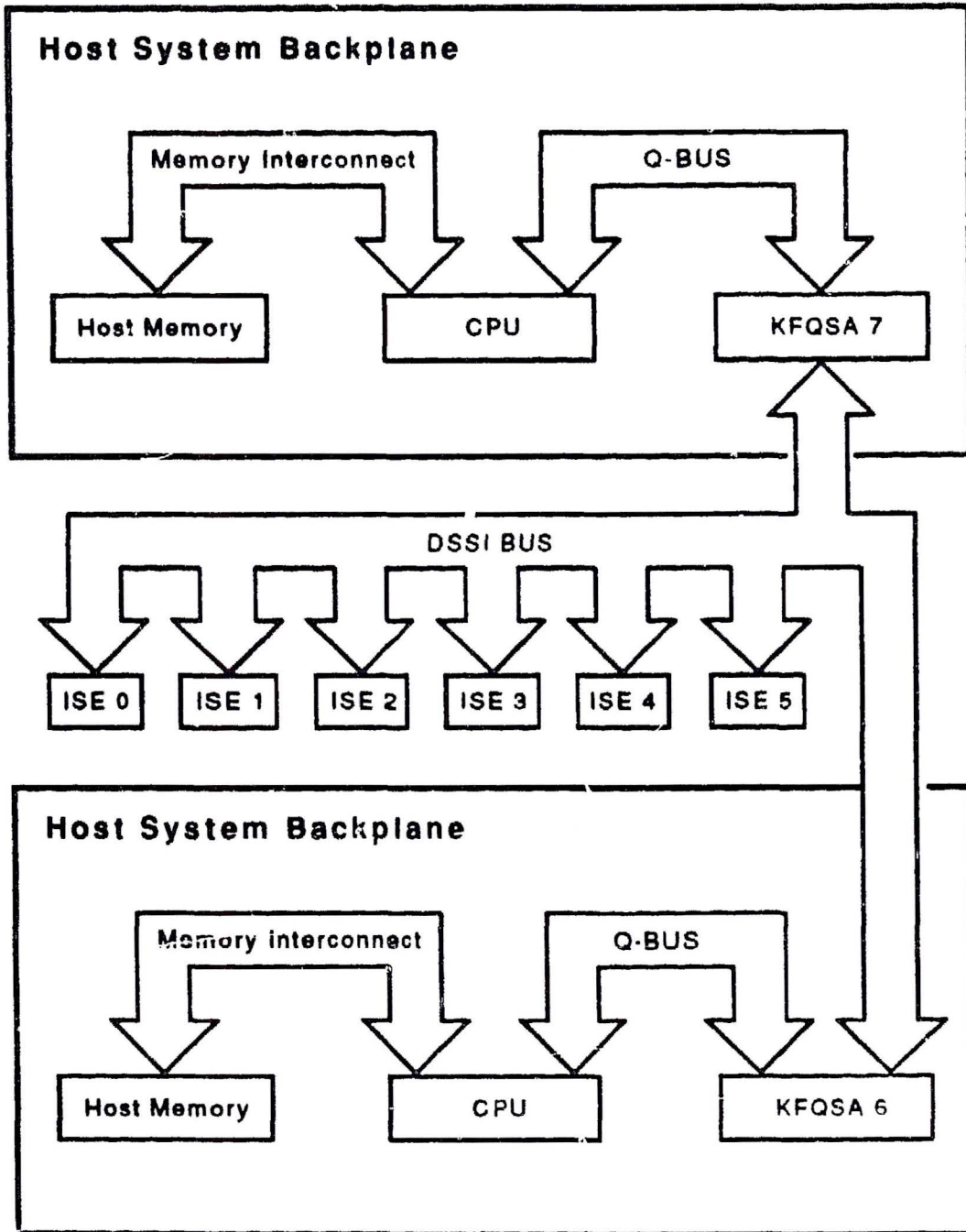
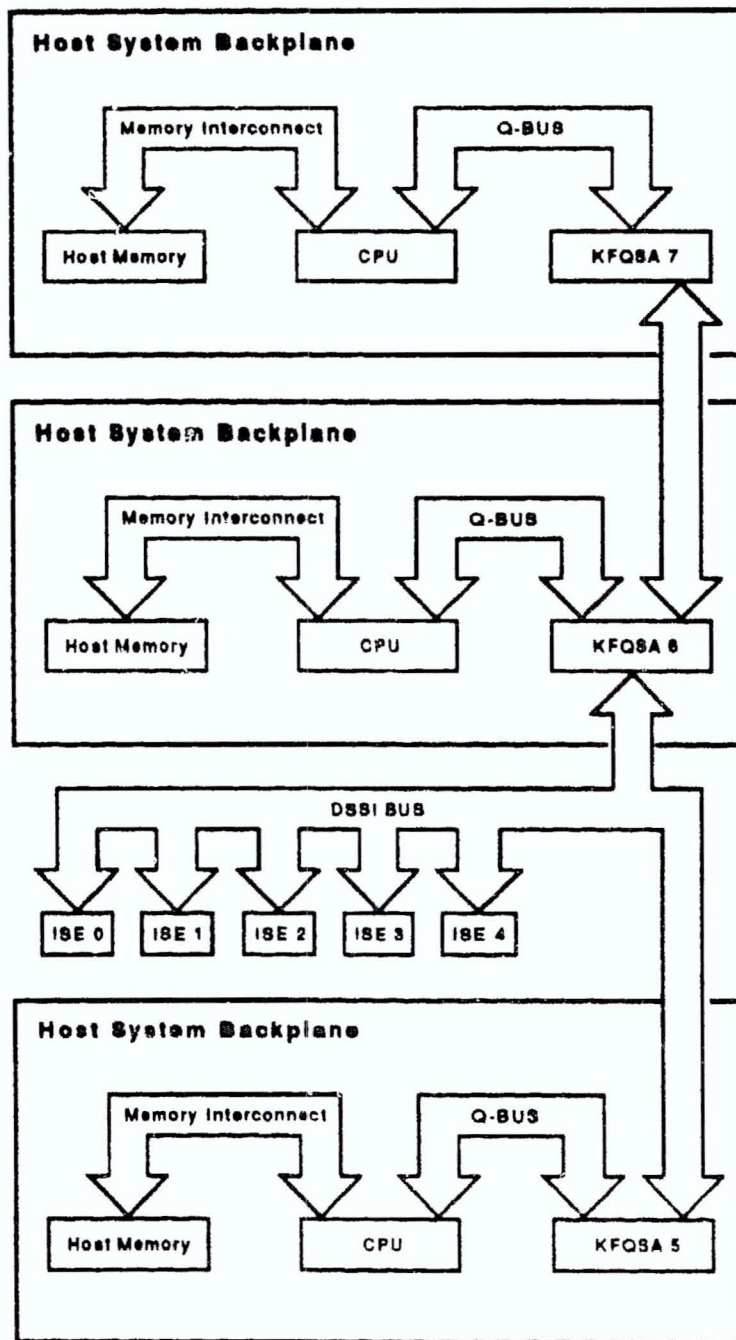

Figure 1-3 DSSI VAXcluster with Three Hosts



1.2 BA440 System Enclosure

The BA440 pedestal enclosure (Figure 1-4) is used in VAX 4000 systems; it is a free standing enclosure for use in an office environment.

Figure 1-4 BA440 Enclosure

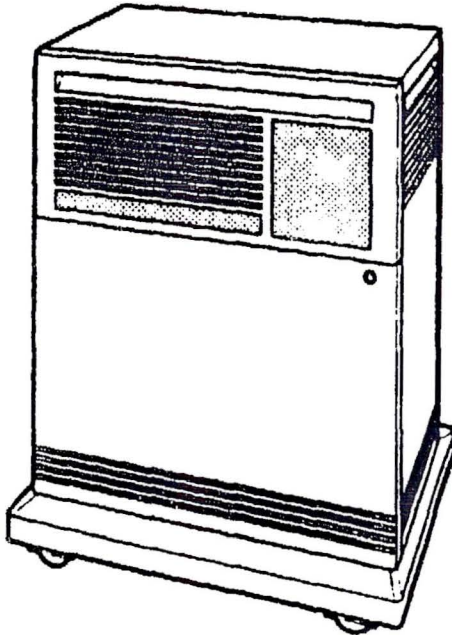

MLO-004032

The BA440 enclosure has a 12-slot, quad-height backplane (Figure 1-5). The backplane is a 21 x 16 inch assembly. The space between each backplane slot varies. The backplane's printed circuit board is an eight-layer, two-sided etch board.

From right to left, the first five backplane slots are for the MS670 memories and the KA670 CPU, while the other seven slots are Q-bus or CD bus slots.

Modules installed in the BA400 and BA200 series enclosures that connect to external devices have bulkhead handles with the I/O connector on the handle. The handles replace the insert panels and internal cabling found in other enclosures. This design is easier to maintain since it eliminates problems caused by faulty internal cabling.

1-6 General Information

Figure 1-5 BA440 Backplane

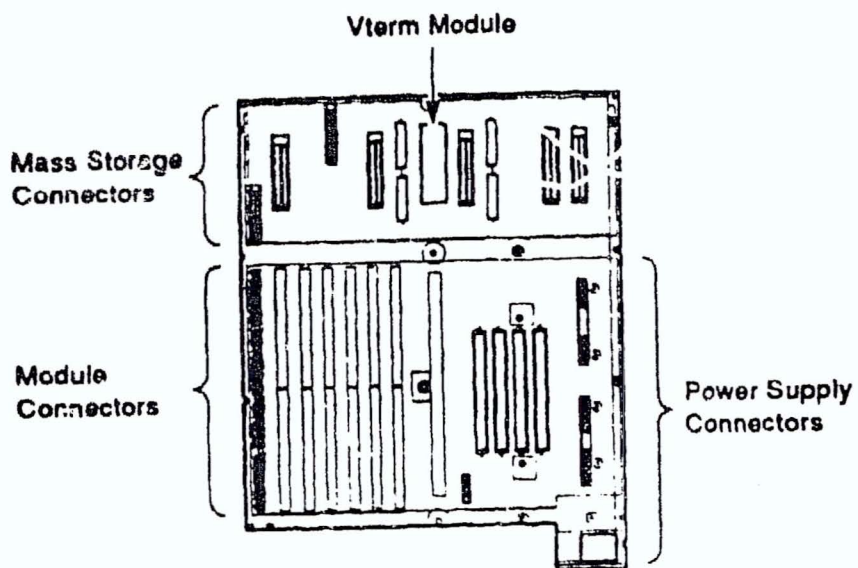

MLO-004201

1.3 BA213 System Enclosure

The BA213 enclosure has a 12-slot, Q-bus backplane and two modular power supplies. Figure 1-6 shows the BA213 enclosure.

The backplane implements the Q-bus on the AB rows of each slot. The CD interconnect is implemented in all slots. MicroVAX systems use the CD rows of slots 1 through 5 for their high-speed memory interconnect.

Figure 1-6 BA213 Enclosure

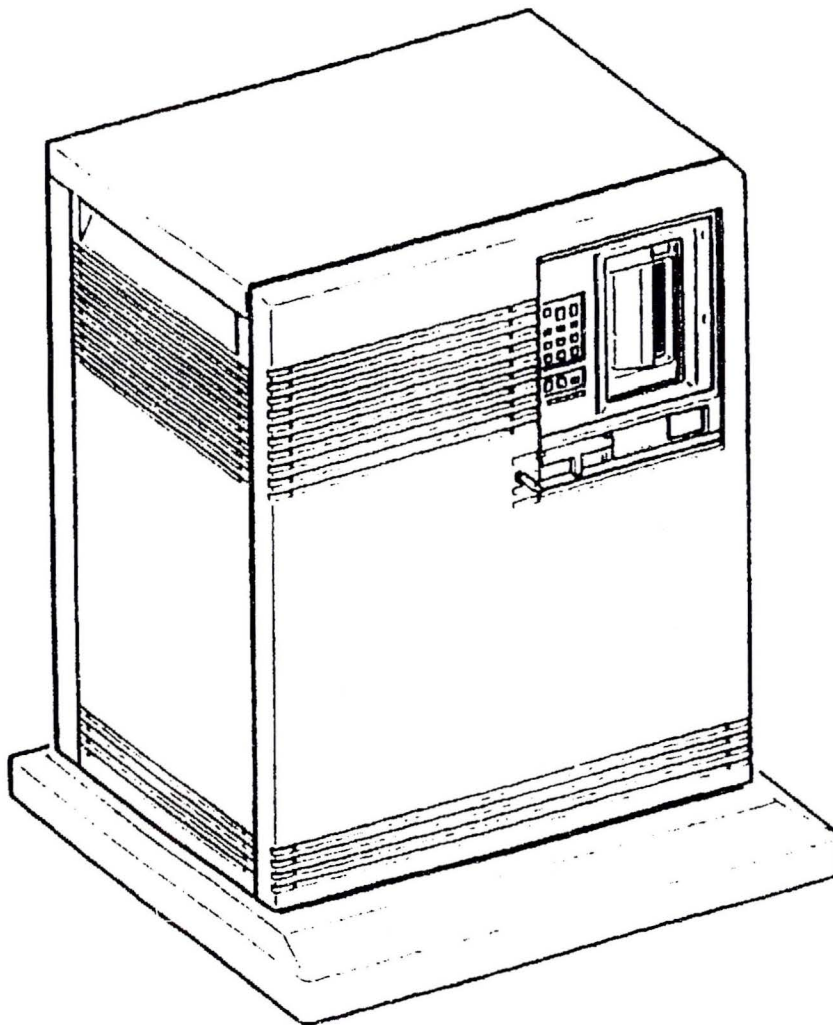

Bus grant signals pass through each installed module through the A connectors of each slot. Figure 1-7 shows the bus grant routing for the BA213 backplane. Use bus grant continuity cards (M9047) in vacant backplane slots to ensure bus continuity.

The BA213 enclosure holds up to four standard 5.25-inch storage devices. Fixed disk drives face the rear of the enclosure, providing easy access to the drive signal and power cables. Tape drives face the front of the enclosure.

The major difference between the BA213 and other microsystem enclosures is in the way you connect modules to external devices. Other enclosures have an I/O panel in the rear of the enclosure. The BA213 uses bulkhead handles or covers that fit over the front of the module. Standard modules have bulkhead handles that are an integral part of the module. Option modules, such as the KFQSA, have a bulkhead cover that performs the same function, but are not attached to the module.

The bulkhead handles and covers form an electrical seal that complies with FCC regulations for keeping radio frequency interference (RFI) generated by the system inside the enclosure, and for keeping externally generated RFI out of the enclosure. They also help guarantee proper airflow through the system for module cooling.

Figure 1-7 BA213 Backplane Bus Grant Continuity Path

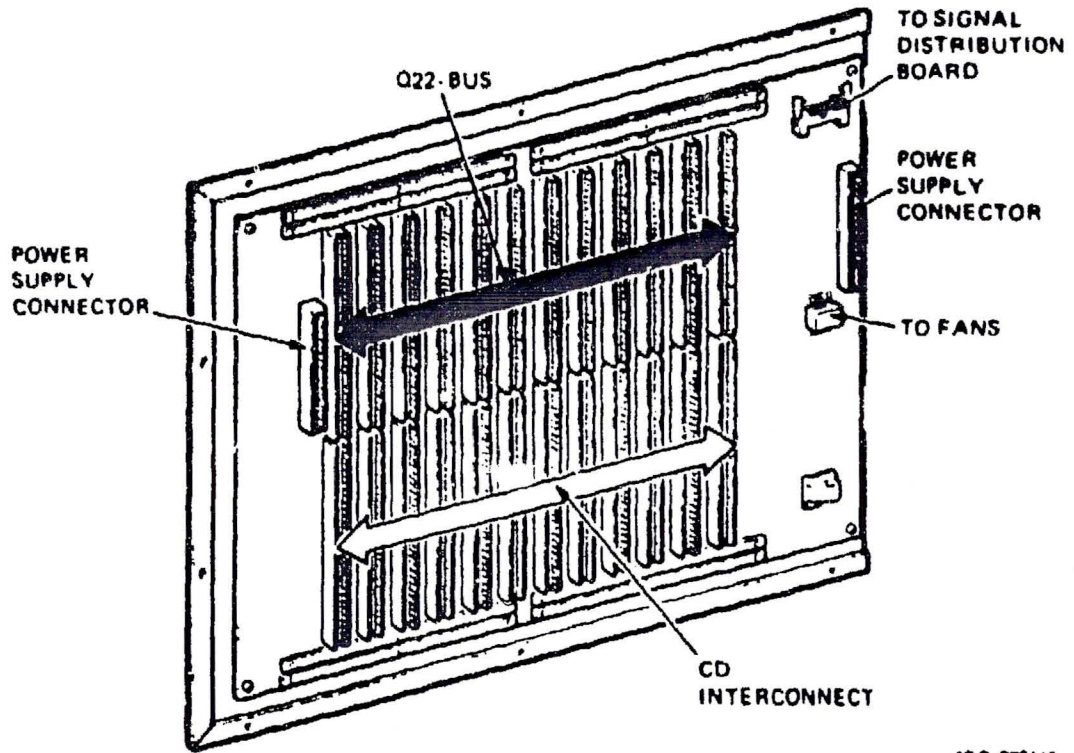

MLO-000119

1.4 BA123 System Enclosure

The BA123 enclosure has a 13-slot, Q-bus backplane and holds up to five 5.25-inch storage devices. Figure 1-8 shows the BA123 enclosure.

The first 12 slots are for dual or quad-height modules. The CD rows of slot 13 are for the signal distribution board. If needed, a second signal distribution board can be installed in the AB rows of slot 13.

Figure 1-8 BA123 Enclosure

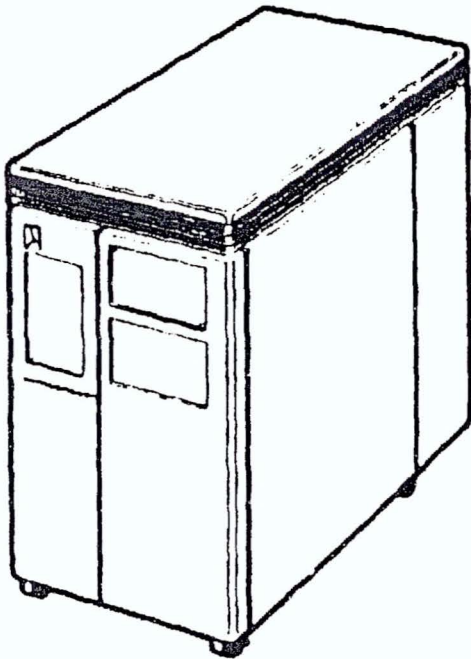

MR 14027

The backplane implements the Q-bus modules on the AB rows of each slot. MicroVAX systems use the CD rows of slots 1 through 4 for their high-speed memory interconnects. Figure 1-9 shows the bus grant continuity path for the BA123 backplane.

You can install the KFQSA and other Q-bus modules in slots 5 through 12. As a rule, if you install a dual-height module in either the AB rows or the CD rows of a slot, you must install another dual-height module or a bus grant continuity card in the other two rows of the slot. The exception to this rule occurs when the dual-height module is installed in the last occupied slot in the card cage.

Figure 1-9 BA123 Backplane Bus Grant Continuity Path

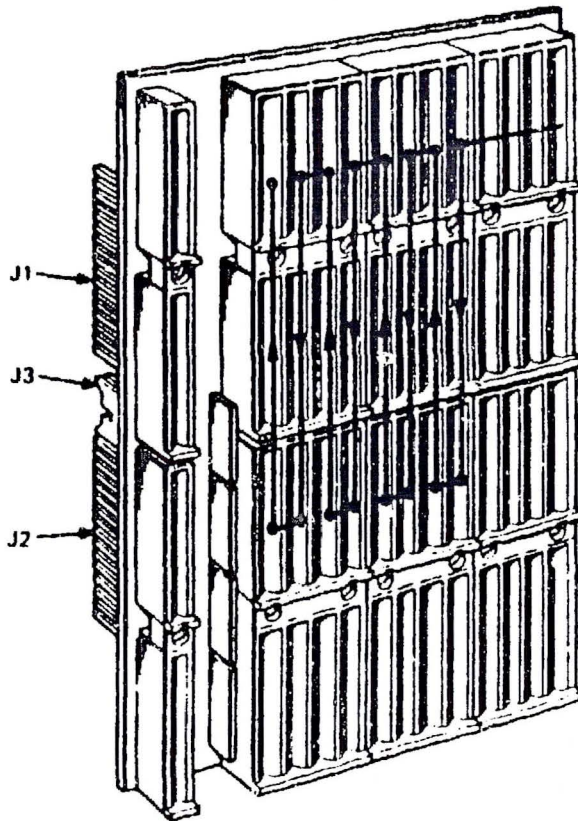

SMR 0238 68

1.5 BA23 System Enclosure

The BA23 enclosure has an 8-slot, Q-bus backplane and holds up to two 5.25-inch storage devices. Figure 1-10 shows the BA23 enclosure.

Figure 1-10 BA23 Enclosure

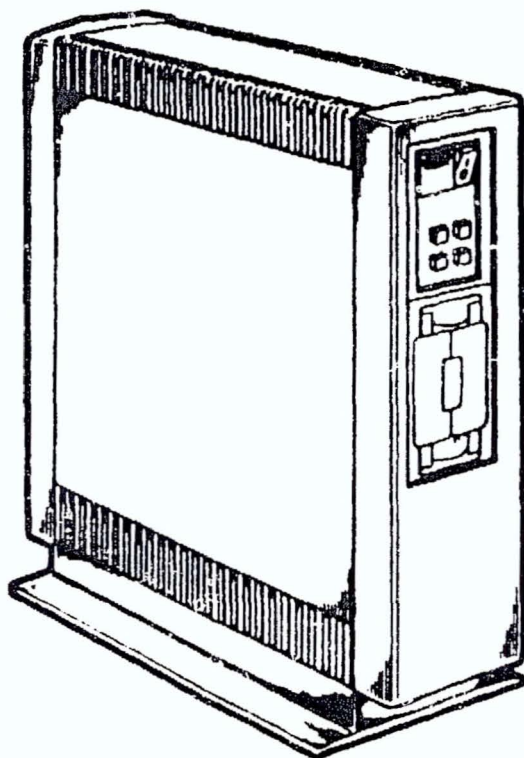

MR 15187

The backplane implements the Q-bus module on the AB rows of each slot. The CD rows of slots 1 through 3 form the MicroVAX memory interconnect. You should install only MS630 memory modules in the CD rows of slots 2 and 3. You can install any dual-height modules in the AB rows of slots 2 and 3. Slot 1 is reserved for the CPU module. Figure 1-11 shows the bus grant continuity path for the BA23 backplane.

You can install the KFQSA and other Q-bus modules in slots 4 through 8. As a rule, if you install a dual-height module in either the AB rows or the CD rows of a slot, you must install another dual-height module or a bus grant continuity card in the other two rows of the slot. The exception to this rule occurs when the dual-height module is installed in the last occupied slot in the card cage.

Figure 1-11 BA23 Backplane Bus Grant Continuity Path

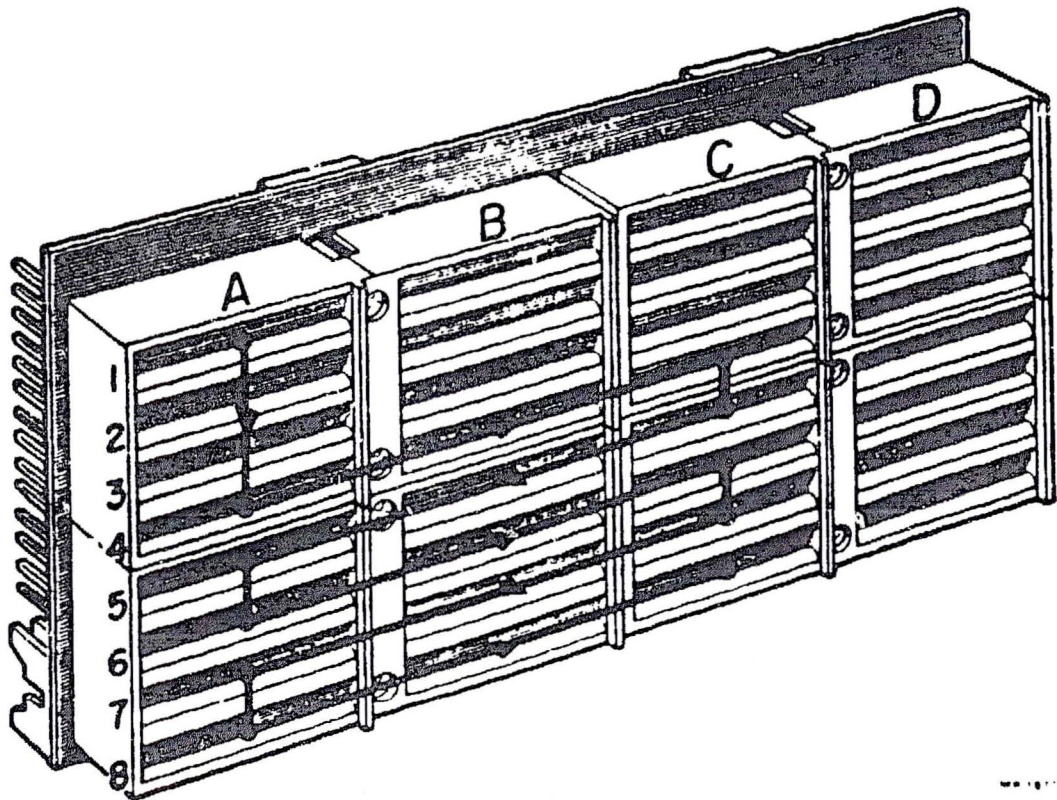

1.6 DSSI VAXcluster Configurations

DSSI ISEs have a capability built into their firmware that allows the ISE to maintain simultaneous connections with more than one host system.

A DSSI VAXcluster configuration uses DSSI cables as the interconnect. Q-bus modules for VAX or MicroVAX systems interface to DSSI cables by means of a DSSI adapter, such as a KFQSA module. Some adapter modules are embedded in the processor module.

As many as 8 DSSI nodes may use the same interconnect. A DSSI node is any device to which DSSI transports information and for which DSSI therefore needs an address, including ISEs and KFQSA modules on VAX or MicroVAX systems.

In a DSSI VAXcluster configuration, the host systems (and possibly an expansion cabinet such as the R215F) are connected together through an external DSSI cable. Each system is a boot server in a Local Area VAXcluster configuration. The host systems may share a common system disk ISE or may have independent system disk ISEs. Each system has direct and equal access to the common system disk ISE through its KFQSA module, and to any other ISE in either enclosure.

Figure 1-12, Figure 1-13, and Figure 1-14 are examples of DSSI VAXcluster configurations using the KFQSA module.

The benefits of a KFQSA-based DSSI VAXcluster configurations are:

- VAXcluster features, such as shared data across systems and satellite nodes
- Simplified system management due to a shared system disk (see the following page)
- Shared batch and print queues
- Higher system availability

NOTE

Systems that use the KFQSA module can only form DSSI VAXcluster configurations with other KFQSA-based systems.

NOTE

DSSI VAXcluster configurations are only supported under VMS Version 5.1-1 and later, and only when the systems are configured into the same Local Area VAXcluster configuration.

NOTE

Due to limitations in the MicroVAX II boot ROMs, two MicroVAX II systems in a DSSI VAXcluster configuration cannot automatically boot from a common system disk ISE. If a common system disk is used, each node in the DSSI VAXcluster configuration must boot from a different root (SYS0, SYS1). But the MicroVAX II system can only boot automatically from SYS0. It is recommended that each MicroVAX II system have its own locally connected system disk (such as an RD54 or RA82). When a common system disk ISE is a requirement, one MicroVAX II system may automatically boot from SYS0 but the other must be booted manually from SYS1.

When a MicroVAX II system is clustered (DSSI VAXcluster configuration) with a MicroVAX 300 series system, the MicroVAX II system should boot from SYS0 and the MicroVAX 300 series system should boot from an alternate root.

Figure 1-12 Two-System DSSI VAXcluster Configuration

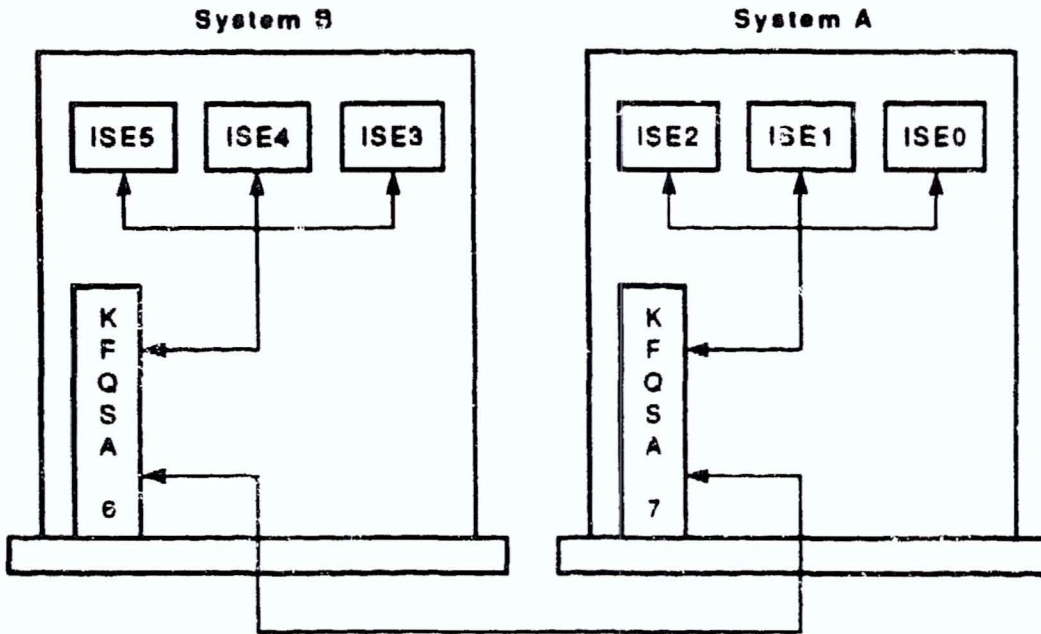

LJ-01734-T10

Figure 1-13 Three-System DSSI VAXcluster Configuration

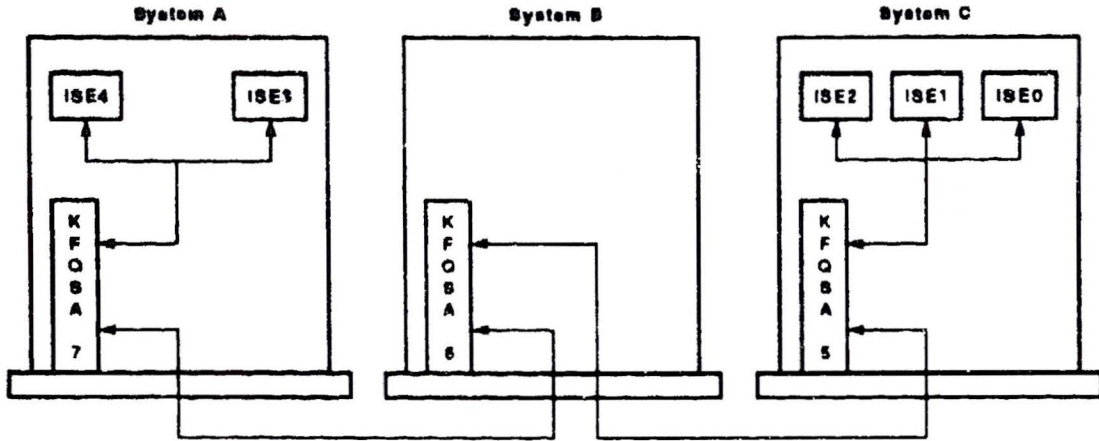

LJ 01710 T10

Figure 1-14 DSSI VAXcluster with an Expansion Cabinet

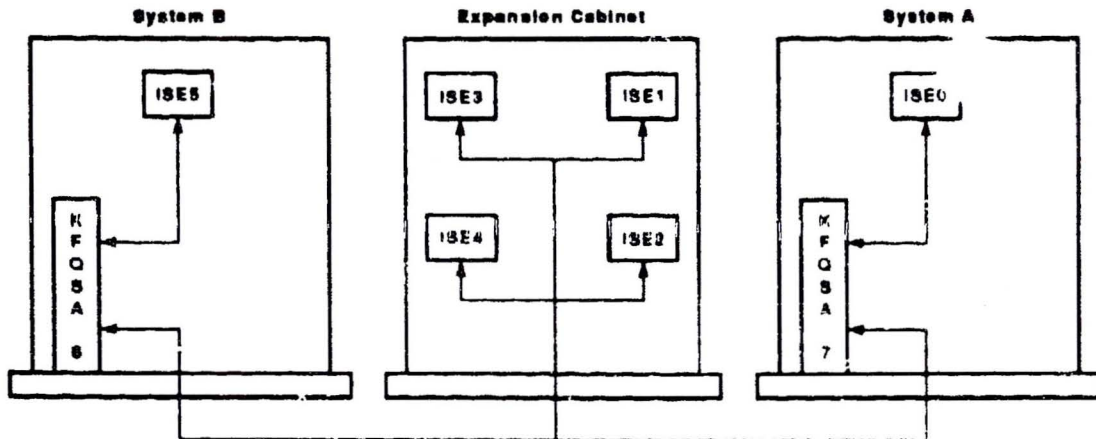

LJ 01710 T10

2

Unpacking Instructions

Unpacking consists of removing the adapter and cables from the shipping container, verifying that there are no missing parts, and inspecting for damage. Report any damages or shortages to the shipper, and notify Digital Services.

Before opening the container, check for external damage such as dents, holes, or crushed corners. Open and unpack the shipping container. Inventory the contents of your option kit using Table 2-1.

NOTE

The KFQSA module is in an antistatic wrapping with a silica gel packet to prevent moisture damage. Do *not* unpack the module until antistatic precautions have been taken. Save the wrapping and the gel packet to protect any modules that are being stored or transported.

2.1 Option Kits

The KFQSA is shipped as part of an option kit. Each option kit includes an adapter board, preconfigured cabling, a terminator, mounting hardware, and documentation. Table 2-1 lists the option kits that are offered for field installation, and the parts that are included in each kit.

2-2 Unpacking Instructions

Table 2-1 KFQSA Option Kits

Option Kit	Part Description	Part Number
KFQSA-SA (factory installed, for reference only)	KFQSA module	M7769
	DSSI device cable (flat)	17-01836-01
	DSSI adapter cable (round)	17-01931-01
	External terminator	12-29258-01
	KFQSA installation manual	EK-KFQSA-IN
KFQSA-SG (for BA113, with cable for external ISEs only)	KFQSA module	M7769
	KFQSA add-on cable	70-26020-02
	External terminator	12-29258-01
	KFQSA module label	36-26883-96
	Gap filler panel	70-24071-01
	KFQSA installation manual	EK-KFQSA-IN
KFQSA-BA (for BA123, with cable for external ISEs only)	KFQSA module	M7769
	KFQSA add-on cable	17-01835-02
	External terminator	12-29258-01
	Mounting screws (Q-bus mounting plate)	90-09701-00
	KFQSA installation manual	EK-KFQSA-IN
KFQSA-AA (for BA23, with cable for external ISEs only)	KFQSA module	M7769
	KFQSA add-on cable (BA23) ¹	17-01835-01
	KFQSA add-on cable (H9642) ¹	17-01835-04
	External terminator	12-29258-01
	Mounting screws (Q-bus mounting plate)	90-09701-00
	KFQSA installation manual	EK-KFQSA-IN

¹Use only one of these cables, as appropriate for the installation.

2.2 Inspection

CAUTION

Printed circuit boards can be damaged by static electricity. When handling the KFQSA module, wear an antistatic wrist strap and use a grounded work surface such as the one in the Antistatic Kit (PN 29-26246).

1. Visually inspect the KFQSA for damage. Check the components and connectors for broken, bent, or missing pins. If there is any damage, do not continue with the installation.
2. Check for the presence of the jumper shown in Figure 2-1. The KFQSA should never be installed with this jumper in place. If it is on the module, remove it.

Figure 2-1 KFQSA Jumper Location

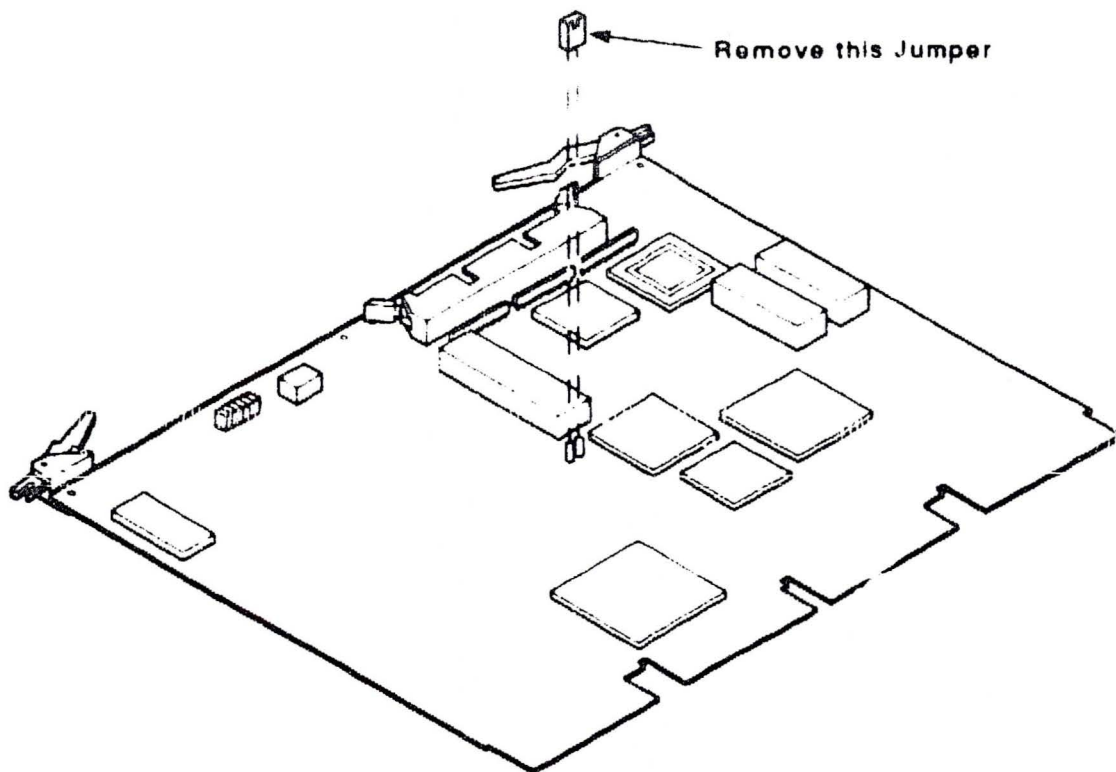

3

Planning the System Installation

It is important to carefully plan the system installation before putting any new modules into the system. This involves checking the power and bus load requirements, and checking to make sure you have everything you need to make the configuration work.

Fill out a configuration worksheet before proceeding with the installation. A configuration worksheet lets you track the parameters that limit system configuration such as space, power requirements, and bus loads.

Figure 3-1, Figure 3-2, Figure 3-3, and Figure 3-4 are examples of a configuration worksheets for the BA440, BA213, BA123, and BA23 enclosures, respectively. Table 3-1 lists power and bus load data for all currently supported modules and storage devices

Complete the configuration worksheet by performing the following steps:

1. List all devices already installed in the system.
2. List all devices you plan to install in the system.
3. Fill in the power and bus load data from Table 3-1 for each device you have listed.
4. Add the columns and make sure the totals are within the limits specified for the enclosure.

3-2 Planning the System Installation

Figure 3-1 BA440 Configuration Worksheet

SLOT	MODULE	Current (Amps)		+3.3 -12		Power (Watts)	Bus Load	
		+5 Vdc	+12 Vdc				AC	DC
1								
2								
3								
4	L4001-BA	2.52	0.0			12.6		
5	L4000-A/B	7.4	0.35			42.6		
6								
7								
8								
9								
10								
11								
12								
H3604		1.7	0.5			17.5		
MASS STORAGE:								
0	TK70	1.5	2.4			36.0		
1								
2								
3								
Total these columns:								
Must not exceed:		60.0 A	18.0 A			584.0 W		

Note: Total output power from +3.3 Vdc and +5 Vdc must not exceed 330 W

MLO-003830

Figure 3-2 BA213 Configuration Worksheet

RIGHT POWER SUPPLY

SLOT	MODULE	Current (Amps)		Power (Watts)
		+5 Vdc	+12 Vdc	
1				
2				
3				
4				
5				
6				
MASS STORAGE				
	TK Drive			
	FIXED DISK			
Total these columns				
Must not exceed		33 0 A	7 0 A	230 0 W

LEFT POWER SUPPLY

SLOT	MODULE	Current (Amps)		Power (Watts)
		+5 Vdc	+12 Vdc	
7				
8				
9				
10				
11				
12				
MASS STORAGE:				
	FIXED DISK(S)	1		
		2		
Total these columns				
Must not exceed		33 0 A	7 0 A	230 0 W

3-4 Planning the System Installation

Figure 3-3 BA123 Configuration Worksheet

ADD THESE COLUMNS

SLOT	MODULE	REGULATOR A			REGULATOR B			I/O INSERTS	
		CURRENT +5 VDC	(AMPS) +12 VDC	POWER (WATTS)	CURRENT +5 VDC	(AMPS) +12 VDC	POWER (WATTS)	(2 x 3) B	(1 x 4) A
1	AB								
	CD								
2	AB								
	CD								
3	AB								
	CD								
4	AB								
	CD								
5	AB								
	CD								
6	AB								
	CD								
7	AB								
	CD								
8	AB								
	CD								
9	AB								
	CD								
10	AB								
	CD								
11	AB								
	CD								
12	AB								
	CD								
13	AB	SIGNAL							
	CD	DIST	0.52	2.60					
MASS STORAGE SHELF DEVICE									
5									
4									
3									
2									
1									
COLUMN TOTALS									
MUST NOT EXCEED		36 A	7 A	230 W	36 A	7 A	230 W	6	4**

*RECOMMENDED FOUR DRIVES MAXIMUM TWO IN SHELVES 1 AND 2 TWO IN 3 4 OR 5
 **IF MORE THAN FOUR 1 X 4 I/O PANELS ARE REQUIRED AN ADAPTER TEMPLATE MAY BE USED

Figure 3-4 BA23 Configuration Worksheet

ADD THESE COLUMNS

BACKPLANE SLOT	MODULE	CURRENT (A)		POWER (W)	I/O PANEL INSERTS	
		+5 V	+12 V		B	A
1 AB						
1 CD						
2 AB						
2 CD						
3 AB						
3 CD						
4 AB						
4 CD						
5 AB						
5 CD						
6 AB						
6 CD						
7 AB						
7 CD						
8 AB						
8 CD						
MASS STORAGE						
1						
2						
COLUMN TOTALS						
MUST NOT EXCEED		36.0	7.0	230	4	2*

* IF MORE THAN TWO TYPE A FILTER CONNECTORS ARE REQUIRED AN ADAPTER TEMPLATE (PN 74-27740-01) MAY BE USED THIS ALLOWS THREE ADDITIONAL TYPE A FILTER CONNECTORS BUT REDUCES THE AVAILABLE TYPE B CUTOUTS TO TWO.

3-6 Planning the System Installation

Table 3-1 Power and Bus Load Data

Option	Module	Current (Amps)		Power Watts	Bus Loads	
		+5 V	+12 V		AC	DC
AAV11-D ¹	A1009	1.8	0.0	9.0	1.0	1.0
ADQ32-SA	A030	4.45	0.0	22.25	2.5	0.5
ADV11-D ¹	A1008	3.2	0.0	16.0	1.0	1.0
AXV11-SA	A026-PA	2.0	0.0	10.0	1.2	0.3
CXA16	M3118-YA	1.4	0.11	8.3	3.0	1.5
CXB16-M	M3118-YB	2.0	0.0	10.0	3.0	0.5
CXY08	M3119-YA	1.4	0.35	11.2	3.0	1.5
DEQA	M7504	3.5	0.5	23.5	2.8	0.5
DEQA-SA	M3127-PA	2.4	0.22	14.64	2.2	0.5
DFA01-AA	M3121-PA	1.97	0.04	10.30	3.0	1.0
DHV11	M3104	4.5	0.55	29.1	2.9	0.5
DLVJ1	M8043	1.0	0.25	8.0	1.0	1.0
DMV11-M	M8053	3.4	0.4	21.8	2.0	1.0
DMV11-N	M8064	3.4	0.4	21.8	2.0	1.0
DFV11	M8020	1.2	0.3	9.6	1.0	1.0
DRQ3B-SA	M7658-PA	4.5	0.0	22.50	2.0	0.5
DRV11	M7941	0.9	0.0	4.5	2.8	1.0
DRV11-J	M8049	1.8	0.0	9.0	2.0	1.0
DRV1W-SA	M7651-PA	1.8	0.0	9.00	2.0	1.0
DSV11	M3108	5.43	0.69	35.43	3.9	1.0
DTQNA-BC	M7130	6.0	2.0	54.00	3.9	0.5
DZQ11	M3106	1.0	0.36	9.32	1.5	1.0
DZV11	M7957	1.2	0.39	10.7	3.9	1.0

¹Usually connected through a universal data input panel (UDIP) using a 5.25-inch mass storage slot

Table 3-1 (Continued) Power and Bus Load Data

Option	Module	Current (Amps)		Power Watts	Bus Loads	
		+5 V	+12 V		AC	DC
H3604 ²	-	1.70	0.50	14.50	-	-
IBQ01-SA	M3125-PA	5.00	0.03	28.60	4.6	1.0
IEQ11	M8634	3.0	0.0	15.0	2.0	1.0
KA630-AA	M7606	6.2	0.14	32.7	2.7	1.0
KA670-A/B ³	L4000-A/B	7.4	0.35	41.20	4.0	1.0
KDA50-Q	M7164	6.93	0.0	34.65	3.0	0.5
KDA50-Q	M7165	6.57	0.03	33.21	0.0	0.0
KFQSA	M7769	5.5	0.0	27.0	3.8	0.5
KLESI	M7740	3.0	0.0	15.0	2.3	1.0
KMV11	M7500	2.6	0.2	15.4	3.0	1.0
KRQ50-SA	M7552	2.7	0.0	13.50	2.7	1.0
KWV11-C ¹	M4002	2.2	0.013	11.2	1.0	1.0
KXJ11-SF	M7616	6.0	1.4	46.80	2.7	1.0
LPV11-SA	M8086-PA	2.8	0.0	14.00	1.8	0.5
LPV11	M8027	0.8	0.0	4.0	1.4	1.0
MRV11-D	M7942	2.8	0.0	14.0	1.8	1.0
MS630-AA	M7607	1.0	0.0	5.0	-	-
MS630-BA	M7608	1.3	0.0	6.5	-	-
MS630-CA	M7609	2.1	0.0	10.5	-	-
MS670-BA	L4001-BA	2.52	0.0	12.60	-	-
RC25	-	1.0	2.5	35.0	-	-
RD51	-	1.0	1.6	24.2	-	-
RD52	-	1.0	2.5	35.0	-	-
RD53	-	0.9	2.5	34.5	-	-

¹Usually connected through a universal data input panel (UDIP) using a 5.25-inch mass storage slot

²Also include -12 Vdc @ 0.25 A, 3 W

³Also include 3.3 Vdc @ 0.27 A, 0.9 W and -12 Vdc @ 0.04 A, 0.5 W

3-8 Planning the System Installation

Table 3-1 (Continued) Power and Bus Load Data

Option	Module	Current (Amps)		Power	Bus Loads	
		+5 V	+12 V	Watts	AC	DC
RD54	-	1.3	1.34	23.7	-	-
RF30	-	1.25	2.85	18.3	-	-
RF31E-AA	-	1.0	2.8	38.60	-	-
RF71	-	1.25	4.54	26.5	-	-
RQDX2	M8639-YB	6.4	0.1	33.2	2.0	1.0
RQDX3	M7555	2.48	0.06	13.2	1.0	1.0
RQDXE	M7513	0.8	0.0	4.0	1.0	0.0
RRD50	M7552	-	-	-	-	-
RX33	-	0.5	0.3	5.6	-	-
RX50	-	0.85	1.8	25.9	-	-
TK50	-	1.35	2.4	33.55	-	-
TK70E-AA	-	1.5	2.4	36.30	-	-
TQK50	M7546	2.9	0.0	14.5	2.0	1.0
TQK70-SA	M7559	3.5	0.0	17.50	4.3	0.5
TSV05	M7196	6.5	0.0	32.5	3.0	1.0
TSV05-SA	M7530	6.5	0.0	32.50	1.5	1.5
TSV05-SA	M7206	6.5	0.0	32.50	2.4	1.0
VCB01	M7602	5.0	0.0	25.0	3.0	1.0
VCB02	M7169	5.8	0.75	38.0	3.5	1.0
VCB02	M7168	3.4	0.0	17.0	0.0	0.0

4

KFQSA Switches

Before installing the KFQSA, you must choose a control and status register address (CSR) that will allow the host to access the adapter. A four-position DIP switchpack is provided for this purpose. Figure 4-1 shows the location of the switchpack. Table 4-1 explains the function of each switch.

In most cases you should use one of the dedicated CSR addresses, as this allows a programming address to be selected without the possibility of conflict with other modules in the system. To do this, set the switches as follows:

- Switch 1—ON
- Switch 2—OFF
- Switches 3 and 4—as specified in Table 4-2

4-2 KFQSA Switches

Figure 4-1 KFQSA Adapter Module Switches

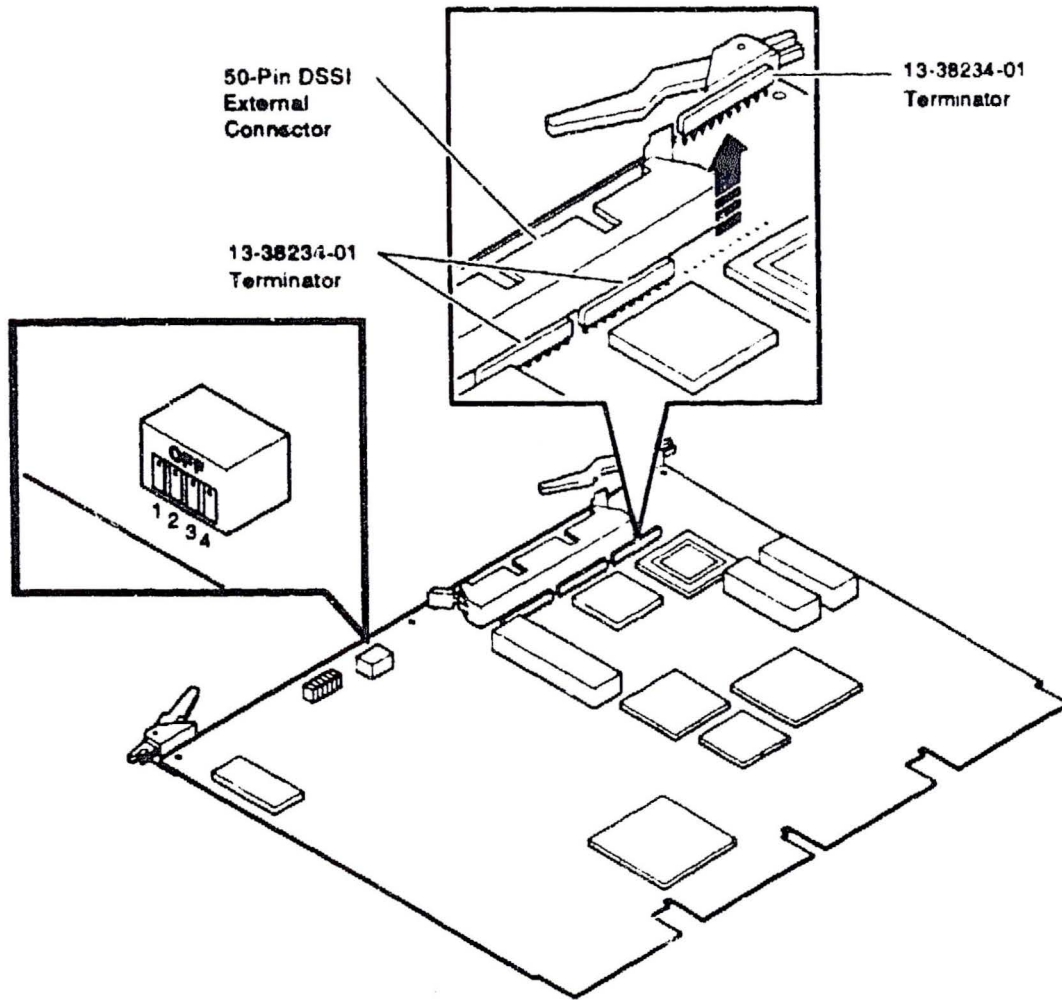

LJ-01722-TD

Table 4-1 KFQSA Switch Settings

Switch	Position	Function
1	OFF	With Switch 1 in the OFF position (toward the number 1,, the other switches are ignored and CSR addresses are read from the configuration table. After the configuration table has been programmed (Chapter 7), the system should be powered down and this switch should be set to the OFF position, where it should remain unless the configuration table is corrupted and needs to be reprogrammed.
	ON	Putting Switch 1 in the ON position enables the selection of a CSR address for programming the configuration table. This is the switch position for the initial installation. The CSR address selected for programming depends on the position of the other three switches.
2	OFF	Putting Switch 2 in the OFF position enables the selection of one of four CSR addresses that have been dedicated for programming the KFQSA. Table 4-2 shows how the remaining two switches are used to select one of these addresses. These addresses should be used <i>only</i> for initially accessing the KFQSA to program the EEROM.
	ON	Putting Switch 2 in the ON position enables the selection of one of four addresses normally reserved for MSCP or TMSCP devices. Table 4-3 shows how the remaining two switches are used to select one of these addresses. ¹
3 and 4		When Switches 1 and 2 are ON and OFF, respectively, these switches are used to select one of four dedicated CSR addresses (Table 4-2).
		When Switches 1 and 2 are both ON, these switches are used to select either a disk (MSCP) address or a tape (TMSCP) address (Table 4-3).

¹Avoid using these addresses at this time; they may conflict with other modules in the system. They are provided for future use.

4-4 KFQSA Switches

Table 4-2 Selecting a Dedicated KFQSA CSR Address

Switch 1	Switch 2	Switch 3	Switch 4	CSR Address (Octal)
ON	OFF	ON	ON	0774420 (fixed)
ON	OFF	ON	OFF	0774424 (fixed)
ON	OFF	OFF	ON	0774430 (fixed)
ON	OFF	OFF	OFF	0774434 (fixed)

Table 4-3 Selecting an MSCP or TMSCP CSR Address

Switch 1	Switch 2	Switch 3	Switch 4	CSR Address (Octal)
ON	ON	ON	ON	0760444 (secondary TMSCP address)
ON	ON	ON	OFF	0774500 (primary TMSCP address)
ON	ON	OFF	ON	0760334 (secondary MSCP address)
ON	ON	OFF	OFF	0772150 (primary MSCP address)

5

Installation Procedures

This chapter explains how to install the KFQSA module into a host enclosure.

CAUTION

Only qualified Digital Service personnel should attempt to install the KFQSA module. Before starting the procedure, make sure that the system manager has backed up all files. Have the system manager perform a system shutdown of the operating system before turning off power. Make sure the customer has taken these steps before removing any panels from the enclosure.

CAUTION

Static electricity can damage integrated circuits. Always wear a grounded wrist strap and use a grounded work surface, such as the one found in the Antistatic Kit (PN 29-26246) when installing modules.

Before beginning the KFQSA module installation, the system should be tested to verify that it is working correctly. The following procedure is recommended, but may be altered due to on-site circumstances at the discretion of the installer.

1. Have the system manager halt the operating system.

CAUTION

Ensure that all necessary system software is backed up at this time.

2. Initiate the system power-on self-test (POST), and verify that these run successfully. Refer to your system documentation for the appropriate procedures.

5-2 Installation Procedures

3. Boot the appropriate diagnostic monitor, and perform a complete system level diagnostic test. Verify that these run successfully.

Once the previous tests have run successfully, power down the system and proceed to the appropriate section for KFQSA module installation procedures.

5.1 BA440 Installation Procedure Using the KFQSA-SG Option Kit

To gain access to the BA440 enclosure, there is a three-position lock that determines which controls you can access. The level of access is as follows:

1. Top position opens the upper door only.
2. Middle position locks both doors.
3. Bottom position opens both doors together.

To install the KFQSA adapter module, do the following:

1. Insert the key into the lock on the front door. Turn the key to the bottom position.
2. Slide down the window.
3. Put the power switch (I O) in the OFF position (O).
4. Pull the release latch on the front door out and use it as a hand grip to remove the door from the system.
5. Remove the blank cover from the slot where the KFQSA is going to be installed by releasing the ¼-turn captive screws holding it to the card cage. (Check your system documentation for the correct placement of modules in the card cage. The KFQSA is usually installed as the last device on the Q-bus module.)
6. Check the KFQSA module switches to ensure that they are in the correct position to select an appropriate CSR address (Chapter 4).
7. Connect the add-on cable connected to the bulkhead handle to the connector on the KFQSA module (Figure 5-1).
 - a. If using the bulkhead handle (PN 70-26020-02), ensure the on-board SIP terminators (PN 13-38234-01) are removed (Figure 4-1), and connect an external DSSI terminator (PN 12-29258-01) to one of the connectors on the bulkhead covers. SIP terminator removal is supported on KFQSA Revision K04 or later.

- b. If using the bulkhead handle (PN 70-26020-01) ensure the on-board SIP terminators are on the KFQSA module.
8. Slide the KFQSA into the card cage slot, and push in the levers to lock the module into place.
9. Connect the external DSSI cable(s) to the bulkhead cover.
10. Before attaching the bulkhead cover over the KFQSA module, run the POST diagnostics. Make sure that the red LEDs all go out, indicating that the POST diagnostics have completed successfully.
11. Configure the DSSI subsystem following the procedures outlined in the next two chapters. Make sure that Switch 1 on the KFQSA is returned to the OFF position once the configuration procedure is completed.
12. Place the bulkhead cover over the module and attach it to the card cage enclosure. If the KFQSA is installed in a slot next to a module with a recessed handle, install the gap filler assembly as follows.
 - a. Using two screws and one gap filler (PN 70-24071-01), attach the gap filler to the top and bottom of the side of the KFQSA bulkhead cover (Figure 5-2). Make sure the gap filler fits into the tab indentations on the KFQSA bulkhead cover.
 - b. Place the bulkhead cover with the gap filler over the card cage slot.
 - c. Make sure there is correct ground (no open spaces) between the KFQSA and the neighboring module.

5-4 Installation Procedures

Figure 5-1 BA440 Cabling for a KFQSA In a VAX 4000 System

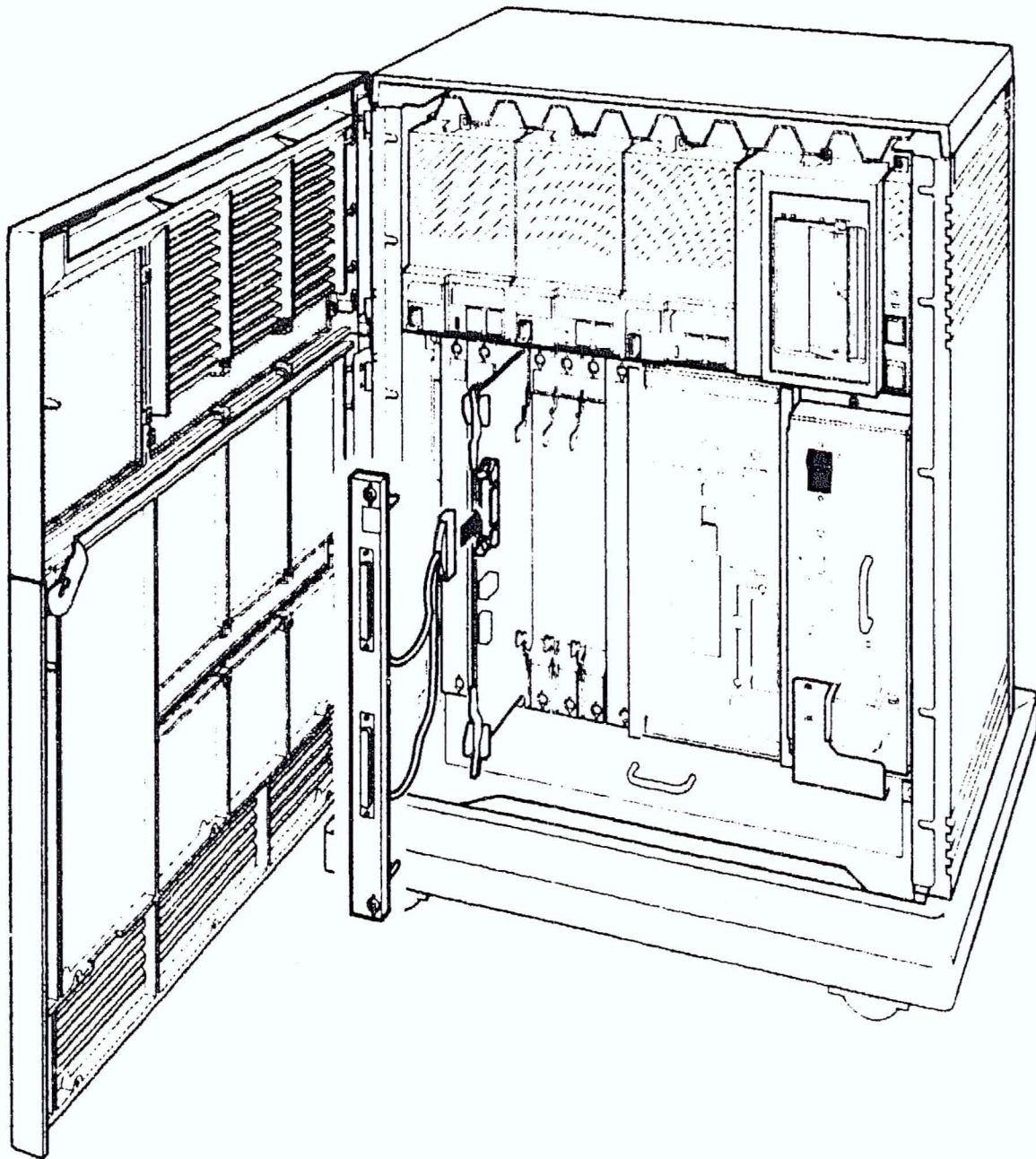

LJ-01724-T10

Figure 5-2 Installing the Gap Filler Assembly

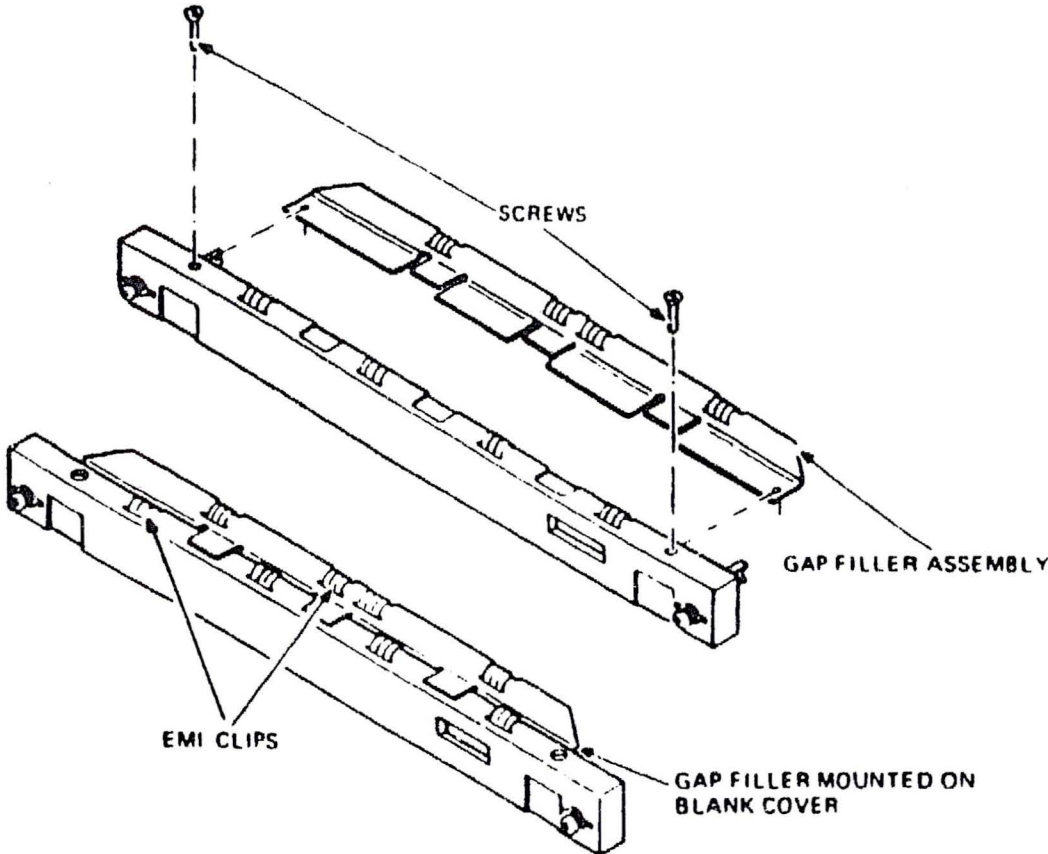

MA 0809A 87
BHR 0038 89

5.2 BA213 Installation Procedure Using the KFQSA-SG Option Kit

The front door of the BA213 enclosure has a 3-position lock that limits access to the system controls. The controls are behind a plastic window at the upper right of the cover.

1. Insert the key into the lock on the front door. Turn the key to the bottom position.
2. Slide down the window.
3. Turn the power switch to the OFF position.
4. Pull the release latch on the front door out and use it as a hand grip to remove the door from the system.
5. Remove the blank cover from the slot where the KFQSA is going to be installed by releasing the ¼-turn captive screws holding it to the card cage. (Check your system documentation for the correct placement of modules in the card cage. The KFQSA is usually installed as the last device on the Q-bus module.)
6. Check the KFQSA module switches to ensure that they are in the correct position to select an appropriate CSR address (Chapter 4).
7. Connect the add-on cable connected to the bulkhead handle to the connector on the KFQSA module (Figure 5-3).
 - a. If using the bulkhead handle (PN 70-26020-02), ensure the on-board SIP terminators (PN 13-38234-01) are removed (Figure 4-1), and connect an external DSSI terminator (PN 12-29258-01) to one of the connectors on the bulkhead cover. SIP terminator removal is supported on KFQSA revision K04 and later.
 - b. If using the bulkhead handle (PN 70-26020-01), ensure the on-board SIP terminators are on the KFQSA module.
8. Slide the KFQSA into the card cage slot, and push in the levers to lock the module into place.
9. Connect the DSSI cable(s) to the bulkhead cover.
10. Before attaching the bulkhead cover over the KFQSA module, run the POST diagnostics. Make sure that the red LEDs all go out, indicating that the POST diagnostics have completed successfully.

Figure 5-3 Cabling for a KFQSA In a Host System Using a BA213 Enclosure

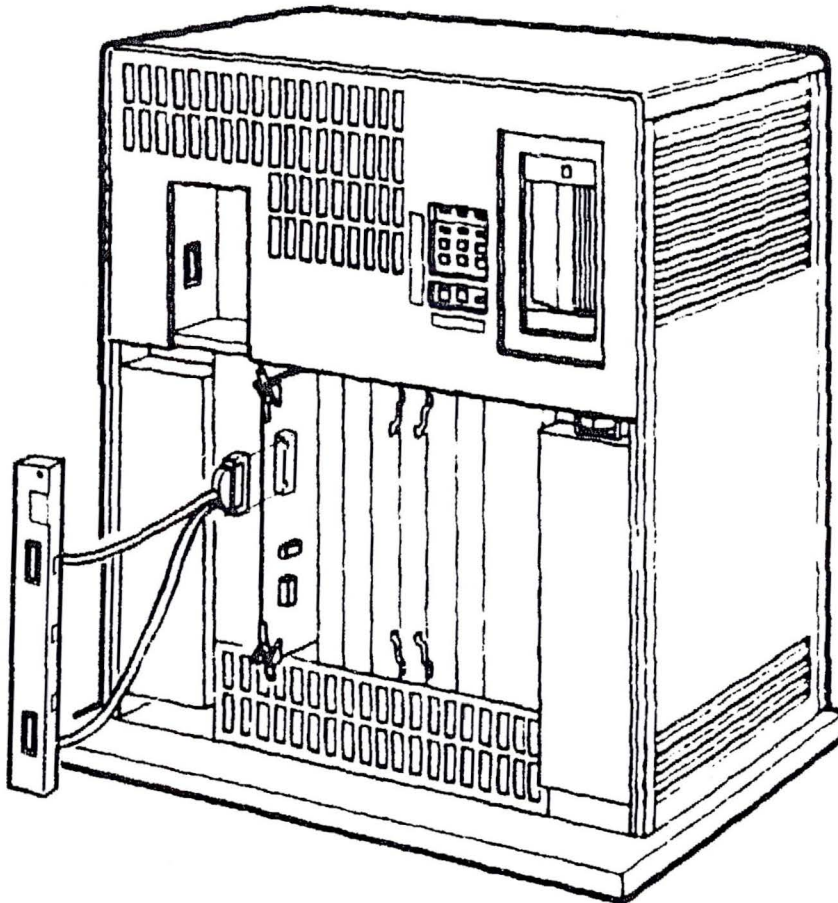

LJ-01716-SCAN

11. Configure the KFQSA ISE subsystem following the procedures outlined in the next two chapters. Make sure that Switch 1 on the KFQSA is returned to the OFF position once the configuration procedure is completed.
12. Place the bulkhead cover over the module and attach it to the card cage enclosure. If the KFQSA is installed in a slot next to a module with a recessed handle, install the gap filler assembly as follows.
 - a. Using two screws and one gap filler (PN 70-24071-01), attach the gap filler to the top and bottom of the side of the KFQSA bulkhead cover (Figure 5-2). Make sure the gap filler fits into the tab indentations on the KFQSA bulkhead cover.

5-8 Installation Procedures

- b. Place the bulkhead cover with the gap filler over the card cage slot.**
- c. Make sure there is correct ground (no open spaces) between the KFQSA and the neighboring module. If necessary, install a gap filler between modules (Figure 5-2).**

5.3 BA123 Installation Procedure Using the KFQSA-BA Option Kit

Refer to Figure 5-4 while performing this procedure.

1. Shut down the enclosure, and remove the ac power cord from the wall outlet.
2. Open the rear door of the enclosure.

Figure 5-4 KFQSA Installation In a BA123 Enclosure

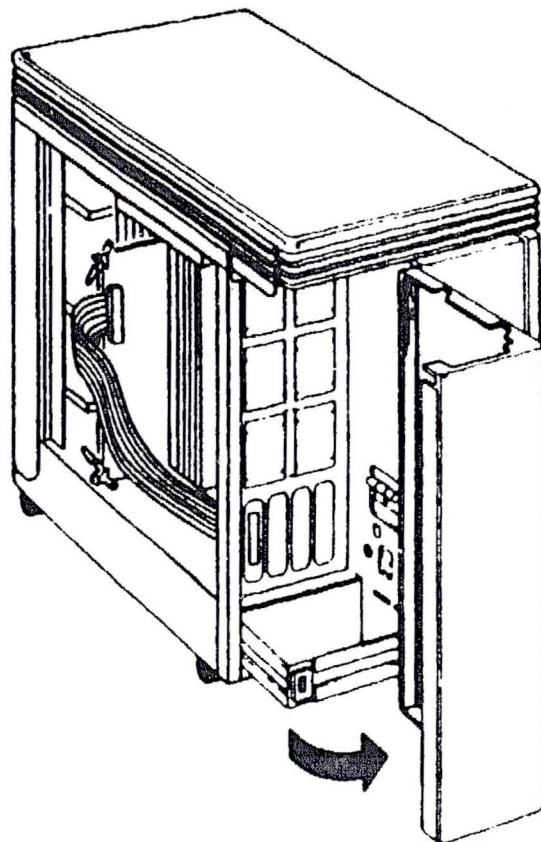

5118 0230 RR

5-10 Installation Procedures

3. Loosen the captive screw that connects the right side panel to the rear of the enclosure (Figure 5-5).
4. The panel is attached to the bottom of the enclosure frame by two snap fasteners. Pull the bottom of the panel out until the panel detaches from the bottom of the enclosure.
5. Lift the panel slightly to release it from the lip at the top of the frame, and remove the panel.

Figure 5-5 Removing the Right Side Panel

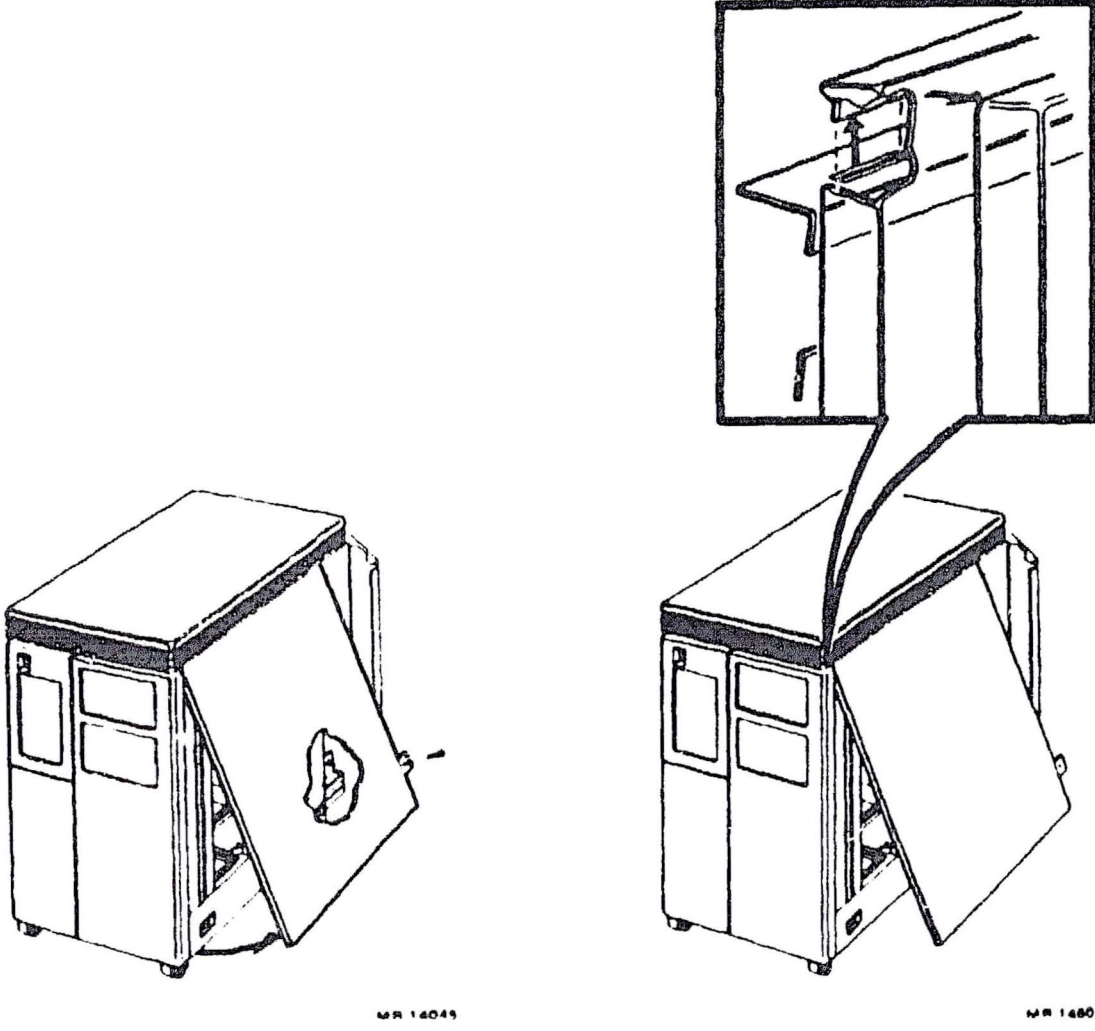

5-12 Installation Procedures

6. Remove the card cage door by releasing the two clasps at the front end of the door, and swing the door open (Figure 5-6).

Figure 5-6 Removing the Card Cage Door

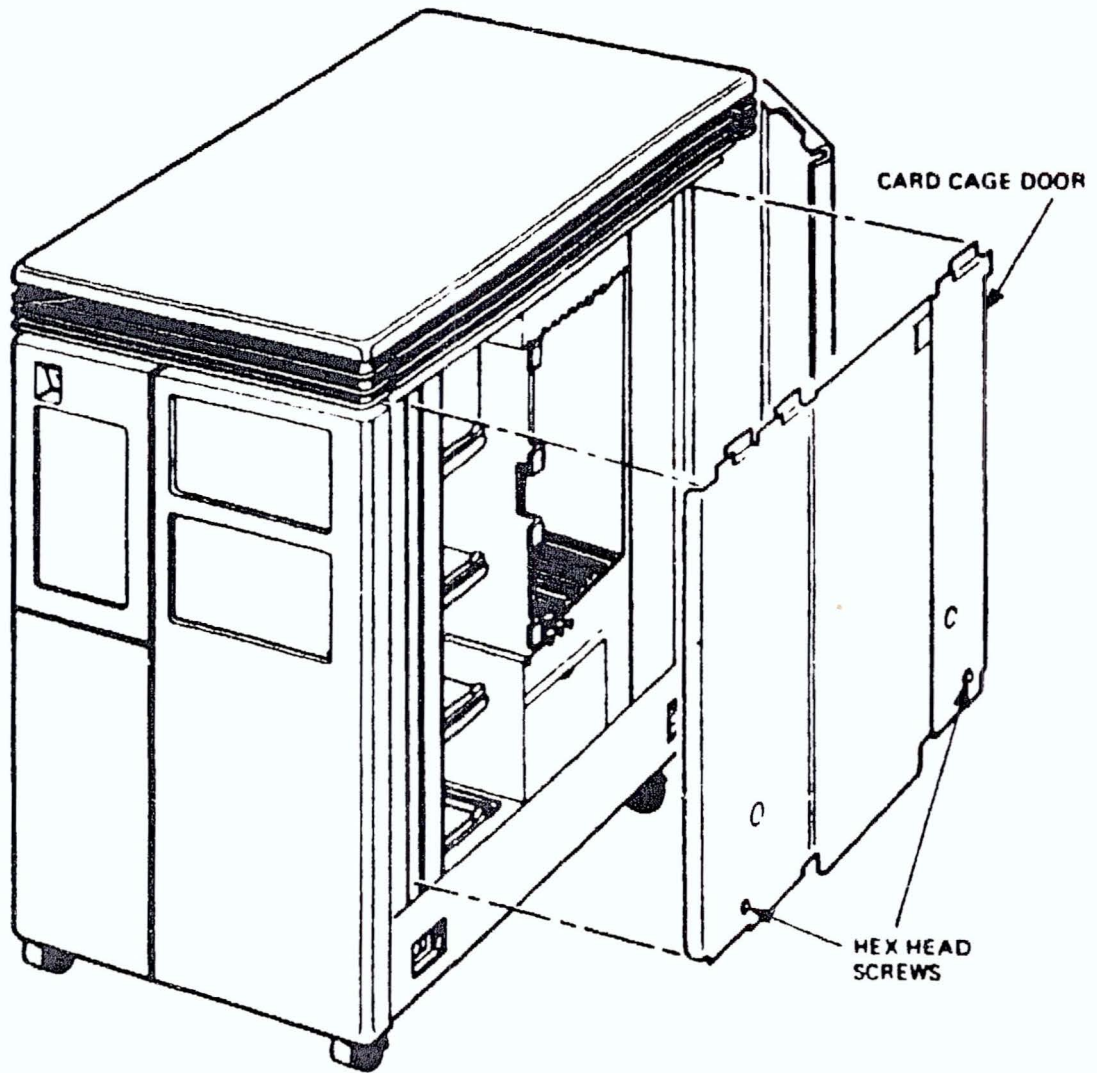

MA 0111 B/A

7. Check to make sure that the KFQSA switches are in the correct position (Chapter 4).
8. Slide the KFQSA module into the appropriate card cage slot and push in the levers to lock the module in place. Refer to your system documentation for the recommended module order.
9. Connect the DSSI cable to the KFQSA module.
10. Install the mounting plate onto the I/O panel, and attach the external DSSI connector to it.
11. Connect the DSSI cable as shown in Figure 5-4.
12. Connect the external terminator, and run the POST diagnostics. Make sure that the red LEDs all go out, indicating that the POST diagnostics have completed successfully.
13. Configure the DSSI subsystem following the procedures outlined in the next two chapters. Make sure that Switch 1 on the KFQSA is returned to the OFF position once the configuration procedure is completed.
14. Assemble the enclosure by reversing Steps 1-6.
15. Remove the external terminator, and connect the DSSI cable from an other host or expansion cabinet to the connector.

5.4 BA23 Installation Procedure Using the KFQSA-AA Option Kit

Refer to Figure 5-7 while performing this procedure.

1. Shut down the enclosure, and remove the ac power cable from the wall outlet.
2. Remove the rear cover and all cables. Label all cables for replacement later.
3. Loosen the two screws retaining the rear I/O panel assembly. Swing the assembly open and remove the ground strap screws.

Figure 5-7 KFQSA Installation In a BA23 Enclosure

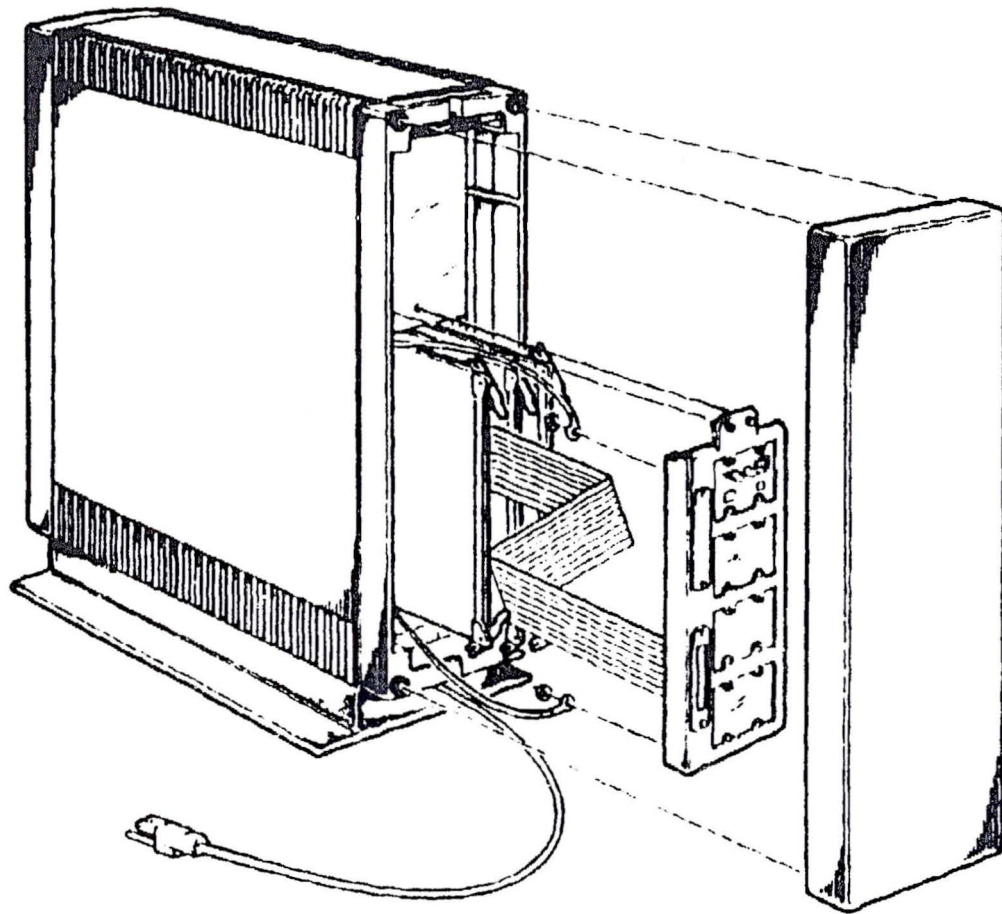

SHR-0278-BA

5-16 Installation Procedures

4. **Disconnect any cables attached to the back of the I/O panel assembly. Note their specific locations and the orientation of the red stripe (keying) on each cable.**
5. **Make sure the KFQSA switches are correctly set (Chapter 4).**
6. **Slide the KFQSA module into the appropriate slot in the backplane. Refer to your system documentation for the recommended module order.**
7. **Attach the DSSI cable to the module.**
8. **Install the mounting plate onto the I/O panel, and attach the external DSSI connector to it.**
9. **Connect the external terminator, and run the POST diagnostics. Make sure that the red LEDs all go out, indicating that the POST diagnostics have completed successfully.**
10. **Replace the I/O panel.**
11. **Configure the DSSI subsystem following the procedures outlined in the next two chapters.**
12. **Remove the I/O panel. Make sure that Switch 1 on the KFQSA module is returned to the OFF position once the configuration procedure is completed.**
13. **Replace the I/O panel and rear cover of the BA23 enclosure.**
14. **Remove the external terminator, and attach the DSSI cable from an other host expansion cabinet to the connector.**

5.5 Installing DSSI VAXcluster Configurations

A DSSI VAXcluster configuration is a highly integrated organization of VAX computers. As members of a DSSI VAXcluster, computers can share processing resources, disks and queues under single VMS security and management software, and can boot and fail independently. DSSI VAXcluster configurations provide a high level of processing and data access.

5.5.1 Types of DSSI Bus Configurations

DSSI Single Host Configuration uses DSSI bus as the interconnect. Q-bus or MicroVAX systems interface to a DSSI bus by means of a DSSI adapter (KFQSA). As many as 8 DSSI *nodes* may use the same interconnect. A DSSI node is any device to which DSSI transports information, and therefore needs an address. In a DSSI single host configuration, the node number for the KFQSA is usually 7.

Two-System DSSI VAXcluster configurations use two host systems to share RF-series ISEs. The maximum number of ISEs that can be accessed by the hosts is 6. The ISEs can be located within each host, within an expander enclosure, or both. A two-host system provides high disk availability for critical applications. In a two-system DSSI VAXcluster configuration, the node numbers for the KFQSAs are 7 and 6.

Three-System DSSI VAXcluster configurations allow the common DSSI bus to share all the resources among the three hosts. In a three host configuration, the middle node (KFQSA6), all the internal terminators are removed from the board (Figure 4-1). The unterminated KFQSA adapter has both an IN and OUT bulkhead connector that allows DSSI bus signals to travel through the adapter to the other hosts. The maximum number of ISEs to be accessed in this configuration is 5.

5.6 Rules for Installing DSSI VAXcluster Systems

There are some restrictions that apply to DSSI VAXcluster systems using the KFQSA module:

- Adapter modules connected to the same DSSI bus when running VMS Version 5.3-1 and earlier must be of the same type.
- The host systems must be in close proximity to each other, due to DSSI bus cable length limitations (measured from end terminator to end terminator). The maximum distance in a three-system configuration is 82 feet in a computer room environment and 65 feet in an office environment.
- All enclosures in a DSSI VAXcluster configuration must be powered from the same ac feed. That is, they must either be powered from the same ac circuit, or if they are powered from different ac circuits, then those circuits must not power any other equipment, must share a single ground point, and must have a dedicated ground wire between the outlet and the single point ground.
- Terminators must reside at the ends of the DSSI bus when configured for multiple hosts.
- All systems must be using VMS Version 5.1-1 or later.
- The maximum of 5 enclosures can be configured on a DSSI VAXcluster; for example, two VAX or MicroVAX systems and three expansion enclosures or three VAX systems and two expansion enclosures.
- Each ISE on a DSSI VAXcluster configuration must appear with the same device name and address on all host nodes.
- A maximum of 3 Q-bus VAX or MicroVAX systems can be present on a DSSI VAXcluster configuration. The middle KFQSA adapter board is unterminated.
- Each node on a single DSSI interconnect must have a unique DSSI ID number, which allows the software to communicate with the storage devices. Numbers must be between 0 and 7; these numbers are permanently associated with the hardware. Node numbers may be repeated on different DSSI interconnects that are connected to the same host systems.

- The length of any single cable between the connectors on DSSI VAXcluster buses is 25 feet.

NOTE

Due to limitations in the MicroVAX II boot ROMs, two MicroVAX II systems in a DSSI VAXcluster configuration cannot automatically boot from a common system disk ISE. If a common system disk is used, each node in the DSSI VAXcluster configuration must boot from a different root (SYS0, SYS1). But the MicroVAX II system can only boot automatically from SYS0. It is recommended that each MicroVAX II system have its own locally connected system disk (such as an RD54 or RA82). When a common system disk ISE is a requirement, one MicroVAX II system may automatically boot from SYS0 but the other must be booted manually from SYS1.

When a MicroVAX II system is in a DSSI VAXcluster configuration with a MicroVAX 3000 or higher series system, the MicroVAX II system should boot from SYS0 and the MicroVAX 3000 or higher series system should boot from an alternate root.

If you are installing more than one system into a DSSI VAXcluster configuration, install each system individually and test it to make sure it is working correctly. When you complete the installation and testing of each system, then reconfigure each system using the procedures in either Chapter 6 or Chapter 7.

This includes:

- Determining correct CSR addresses for all modules in each system
- Reprogramming the KFQSA configuration table for the new configuration
- Reconfiguring any modules whose CSR addresses changed as a result of the new configuration
- Changing the allocation class of the ISEs so they are the same as both hosts

After reconfiguring, remove the terminators and connect the DSSI extension cables between the hosts or expansion cabinets.

6

Programming the DSSI Subsystem Using Console Commands

The KFQSA configuration table may be programmed in two ways, either by using console commands or by using the MicroVAX Diagnostic Monitor (MDM). Using the console commands is the recommended choice if your system has this capability.

To find out if you can use console commands for programming the configuration table, reinitialize the system and read the microcode version that is displayed on the console. If the microcode version is 4.1 or later, the console commands may be used for programming the KFQSA configuration table.

If your system does not have this capability, refer to Chapter 7 for the MDM procedure. If your system does have console commands, perform the procedure described in this chapter.

To find the console commands available, type **HELP** at the console prompt (>>>). To program the KFQSA configuration table, use these commands.

6.1 Determining CSR Addresses

Each module in a Q-bus based system must use a set of unique Q-bus addresses and interrupt vectors. One of these, generally the lowest of the set, is known as the CSR address. The KFQSA emulates an SSP controller¹ for each ISE connected, and presents a separate CSR address for each emulated controller. You must program the KFQSA with a correctly chosen CSR address for every ISE on the DSSI bus. Interrupt

¹ SSP controllers also include the RQDX3, KDA50, RRD50, RQC25, TQK50, and TQK70 controllers. All such ports are identical, and are operated by the same PUDRIVER.

6-2 Programming the DSSI Subsystem Using Console Commands

vectors for the KFQSA (and other SSP controllers) are programmed automatically by the operating system.

Unlike most other Q-bus controllers, KFQSA CSR addresses are not set with switches or jumpers. They are contained in nonvolatile memory on the KFQSA module in the form of a configuration table. To access the configuration table, you must set the switches on the KFQSA to select one of the dedicated addresses shown in Table 4-2. You must ensure the KFQSA is terminated either through on-board SIP terminators or through external DSSI terminators.

Before programming the configuration table, first determine what the CSR addresses should be for all devices on the system. Calculating CSR addresses is a complex procedure because some devices are assigned floating addresses. Floating addresses vary with each module installed on the system.

At the console prompt (>>>), type **CONFIGURE**.

The **CONFIGURE** console command is similar to the VMS **SYSGEN CONFIGURE** utility. It permits the user to enter Q-bus device names, and then generates a table of recommended Q-bus CSR addresses.

After entering the command, the system prompts you for a device and a number. To find which responses are valid, type **HELP**. The system displays:

```
>>>configure
Enter device configuration, HELP, or EXIT
Device, Number? help
Devices:
LPV11      KXJ11      DLV11J     DZQ11      DZV11      DFA01
RLV12      TSV05      RXV21      DRV11W     DRV11B     DPV11
DMV11      DELQA      DEQNA      RQDX3      KDA50      RRD50
RQC25      KFQSA-DISK TQK50      TQK70      TU81E      RV20
KFQSA-TAPE KMV11      IEQ11      DHQ11      DHV11      CXA16
CXB16      CXY08      VCB01      QVSS       LNV11      LNV21
QPSS       DSV11      ADV11C     AAV11C     AXV11C     KWV11C
ADV11D     AAV11D     VCB02      QDSS       DRV11J     DRQ3B
VSV21      IBQ01      IDV11A     IDV11B     IDV11C     IDV11D
IAV11A     IAV11B     MIRA       ADQ32      DTC04      DESNA
IGQ11      KWV32      KZQSA     DIV32      DESQA      KIV32

DTCN5      DTC05

Numbers:
1 to 255, default is 1
Device, Number?
```

Respond by entering the device name and number of each device. After all the devices have been entered, type **EXIT**. For example, if your system has a TK70, three RF30s, and DEQNA devices, you would respond as follows:

```
Device,Number? tk70
Device,Number? kfqsa-disk,3
Device,Number? deqna
Device,Number? exit
```

The system responds with CSR address/vector assignments for all entered devices. For the previous example, the response is:

```
Address/Vector Assignments
-774440/120 DEQNA
-772150/154 KFQSA-DISK
-760334/300 KFQSA-DISK
-760340/304 KFQSA-DISK
-774500/260 TK70
>>>
```

Record the address/vector assignments for use in the next procedure.

6.2 Programming the KFQSA Configuration Table

To program the CSR addresses assigned to the DSSI devices in the previous section, type the following command at the console prompt.

```
>>> set host/uqssp/maintenance/service n
```

NOTE

The */service n* parameter specifies the Controller Number of a KFQSA in SERVICE mode, where *n* is from 0 to 3 (Table 4-2):

- 0 is for CSR address 774420
- 1 is for CSR address 774424
- 2 is for CSR address 774430
- 3 is for CSR address 774434

Typing the following command, displays the current contents of the configuration table. For example, suppose the first address is selected, and the configuration table is currently blank.

6-4 Programming the DSSI Subsystem Using Console Commands

```
>>> set host/uqssp/maintenance/service 0
UQSSP Controller (774420)

Enter SET, CLEAR, SHOW, HELP, EXIT, or QUIT

Node      CSR Address      Model
  7        ----- KFQSA -----
?
```

NOTE

If you cannot access the configuration table, check for correct KFQSA termination. Refer to Chapter 9.

Type **HELP** for a quick reference of the available commands at the ? prompt.

```
? help
```

Commands:

SET <node> \KFQSA	set KFQSA DSSI node ID
SET <node> <CSR_address><model>	enable a DSSI device
CLEAR <node>	disable a DSSI device
SHOW	show current configuration
HELP	print this text
EXIT	program the KFQSA
QUIT	don't program the KFQSA

Parameters:

<node>	0 to 7
<CSR_address>	760010 to 777774
<model>	21 (disk) or 22 (tape)

```
?
```

To add the three RF30 ISEs from the example in the previous section, type the following at the ? prompt:

```
? set 0 772150 21
? set 1 760334 21
? set 2 760340 21
?
```

NOTE

Make sure you enter the addresses in the same order they were given when you used the CONFIGURE command.

Type **SHOW** to display what you just entered.

```
? show
Node      CSR Address      Model
  0        772150          21
  1        760334          21
  2        760340          21
  7        ----- KFQSA -----
?
```

To delete an entry from the table, use the **CLEAR** command. For example, to delete the entry for the ISE with a DSSI node ID of 2, type **CLEAR 2** at the ? prompt.

Type **EXIT** when you have finished programming to **WRITE** the entries to the configuration table.

```
? exit
Programming the KFQSA ...
>>>
```

Power down the system, remove the KFQSA module, and set Switch 1 to the OFF position, enabling the addresses programmed into the configuration table to be read. Then, power the system back up.

To view devices on the Q-bus module, type either **SHOW QBUS** or **SHOW UQSSP** at the console prompt.

The **SHOW QBUS** command displays all Q-bus I/O addresses that respond to a word aligned read. For each address the console displays the address in VAX I/O space (in hex), the address as it would appear in the Q-bus I/O space (in octal), and the word data that was read (in hex).

An example of the **SHOW QBUS** command is as follows:

```
>>> show qbus
Scan of Qbus I/O Space
-200000DC (760334) = 0000 (300) RQDX3/KDA50/RRD50/RQC25/KFQSA-DISK
-200000DE (760336) = 0AA0
-200000E0 (760340) = 0000 (304) RQDX3/KDA50/RRD50/RQC25/KFQSA-DISK
-200000E2 (760342) = 0AA0
-20001468 (772150) = 0000 (154) RQDX3/KDA50/RRD50/RQC25/KFQSA-DISK
-2000146A (772152) = 0AA0
-20001910 (774420) = 0000 (000) KFQSA
-20001912 (774422) = 0AA0
-20001920 (774440) = FF08 (120) DELQA/DEQNA
-20001922 (774442) = FF00
-20001940 (774500) = 0000 (260) TQK50/TQK70/TU81E/RV20/KFQSA-TAPE
-20001942 (774502) = 0BC0

Scan of Qbus Memory Space
>>>
```

6-6 Programming the DSSI Subsystem Using Console Commands

The **SHOW UQSSP** command displays the status of all disk and tape devices that can be found on the Q-bus which supports the SSP protocol. For each device the controller number, CSR address, boot name, and type of device is displayed.

An example of the **SHOW UQSSP** command is:

```
>>> show uqssp
UQSSP Disk Controller 0 (772150)
-DUA0 (RF30)
UQSSP Disk Controller 1 (760334)
-DUB1 (RF30)
UQSSP Disk Controller 2 (760340)
-DUC2 (RF30)
UQSSP Tape Controller 0 (774500)
-MUA0 (TK70)
>>>
```

6.3 Programming the KFQSA Module for a DSSI VAXcluster Configuration

This section describes how to program the KFQSA module when setting up a DSSI VAXcluster configuration. This configuration will always involve two to three KFQSA adapters.

This procedure has three objectives:

1. To configure all KFQSA modules so that they can access all of the ISEs connected on the DSSI bus
2. To give each KFQSA a unique DSSI node ID
3. To configure the KFQSAs and ISEs so that each ISE has a device name that is unique and universal throughout the DSSI VAXcluster configuration

NOTE

All systems should be powered up and displaying the console prompt. The DSSI cables between the host systems should not be connected at this time.

Figure 6-1 and Figure 6-2 are typical block diagrams of DSSI VAXcluster configurations. Using these examples, perform the following procedure on System A.

1. Display the current addresses and devices as follows:

NOTE

Make hardcopy printouts of the displays or write down the information obtained in this step. It will be needed later in this procedure.

- a. Type **SHOW UQSSP** for a display of all SSP controllers currently on the system. This display lists the Q-bus address (octal) and port name of each SSP device on the system. An example of this display is shown in Section 6.2.

6-8 Programming the DSSI Subsystem Using Console Commands

Figure 6-1 KFQSA Modules in a DSSI VAXcluster — Two-System Configuration

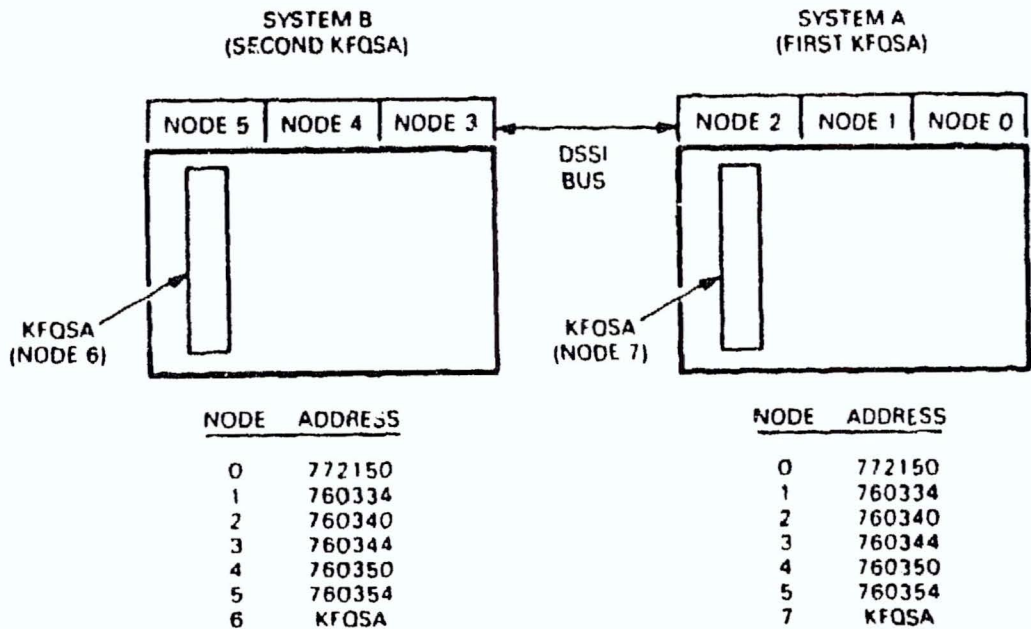

811-R 0035 89

- b. Type **SHOW QBUS** for a display of the eight-digit VAX address (hex) for each device. An example of this display is shown in Section 6.2.
- c. Find the eight-digit VAX address (hex) that corresponds to the Q-bus address for each ISE in the system. Record this information; it will be needed in a later step.

NOTE

In the examples given in Section 6.2 for the **SHOW UQSSP** and **SHOW QBUS** commands, the Q-bus address (772150) for ISE 0 has a corresponding VAX address (hex) of 20001468.

2. Run the Configure utility to determine the correct address for each device and KFQSA modules in the two-system DSSI VAXcluster configuration by performing the following steps. The Configure utility is explained in detail in Section 6.1.
 - a. At the console prompt, type **CONFIGURE**.

Figure 6-2 KFQSA Modules in a DSSI VAXcluster — Three-System Configuration

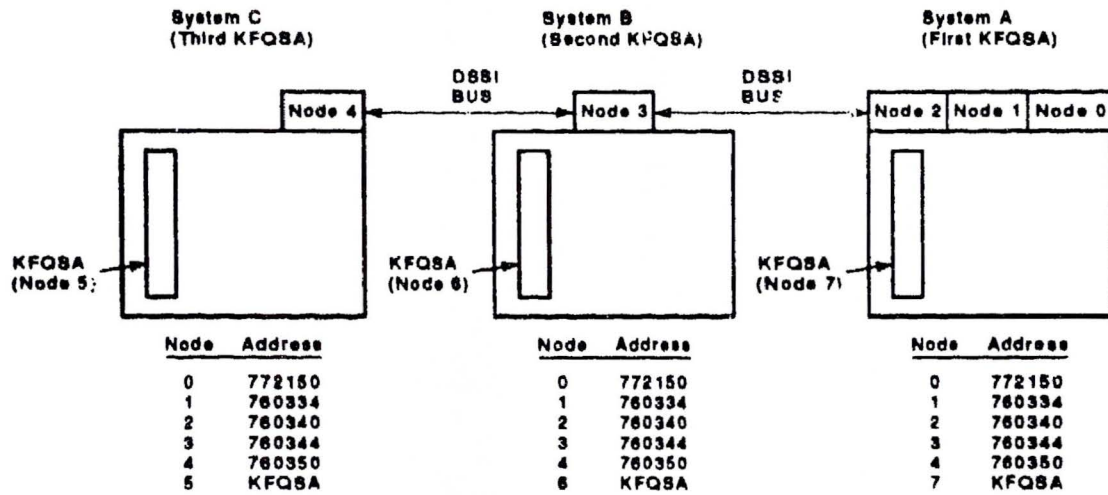

LJ-01717-710

- b. Then type **HELP** at the *Device, Number?* prompt for a list of devices that can be configured.

NOTE

Some devices listed in the HELP display are *not* supported by the KA655-AA CPU.

- c. For each device in the system, type the device name at the *Device, Number?* prompt. If there is more than one of the same device type, enter the device name, a comma, and the total number of devices of that type.

Be sure you list all devices in all systems included in the DSSI VAXcluster configuration.

- d. Type **EXIT**. The Configure utility displays address/vector assignments for all devices entered.
3. Compare the addresses displayed from running the Configure utility with those displayed from the SHOW QBUS display.

Adding the ISEs from the remaining systems in the DSSI VAXcluster configuration may bump the address of another Q-bus device. Make sure that all device addresses, other than those of the ISEs, have not changed. If the device address differs between the two displays, you must reconfigure your system.

6-10 Programming the DSSI Subsystem Using Console Commands

4. Program the KFQSA configuration table in System A by following the procedures outlined in Section 6.2. Make sure to include all ISEs connected to the DSSI bus in the configuration table. Assign a DSSI node ID of 7 to this KFQSA.
5. Repeat Steps 1 through 4 for System B, and if applicable for System C.
6. Program the KFQSA in System B and C by following the procedures outlined in Section 6.2. Make sure to include all ISEs in all systems in the configuration table. Assign a DSSI node ID of 6 to the KFQSA in System B, and 5 to the KFQSA in System C.
7. Power down all systems.
8. Remove the KFQSA modules from all systems, and set Switch 1 to the OFF position.
9. Connect the DSSI cable between all systems.
10. Replace any necessary DSSI unit ID plugs in the Operator Control Panels of each system to make them match the DSSI node IDs assigned to the ISEs for the DSSI VAXcluster configuration.

NOTE

Make sure all DSSI ID sockets in all Operator Control Panels have plugs in them. Use blank plugs in any sockets that do not have corresponding ISEs connected.

11. Power up all systems.
12. For each system:
 - a. Type **SHOW QBUS** to verify that all addresses are present and correct.
 - b. Type **SHOW UQSSP** to verify that all ISEs are displayed correctly.

NOTE

Make sure that the ISEs have been assigned the same DSSI node IDs in all KFQSA configuration tables.

13. Boot one node and note the device names reported by VMS software.
14. Shut down the node and boot another one. Note the device names to ascertain that both systems see the same set of ISE device names. If using a three-system DSSI VAXcluster configuration, repeat this step on the third system.

CAUTION

Make sure that the device name of each ISE is identical on all nodes. Failure to do so can result in a partitioned cluster, and consequently data corruption.

6.4 Setting the ISE Allocation Class

This section describes how to change the ISE allocation class. In a DSSI VAXcluster configuration, you must assign the same nonzero allocation class to both host systems and all connected ISEs. The ISEs are shipped with the allocation class set to zero.

Change the allocation class by using the following procedure.

1. Determine the correct allocation class according to the rules on clustering.

NOTE

In a DSSI VAXcluster configuration, the same allocation class must be assigned to both systems and to all connected ISEs. This allocation class must be different from that of other systems or HSC controllers in a cluster.

2. At the console prompt, type **SET HOST/DUP/UQSSP/DISK # PARAMS**.

Where # is the DSSI node ID of the ISE to which the allocation class is to be set.

3. At the **PARAMS>** prompt, type **SHOW ALLCLASS** to check the current allocation class.

The system responds with the following display.

Parameter	Current	Default	Type	Radix
ALLCLASS	1	0	Byte	Dec B

PARAMS>

4. Type **SET ALLCLASS #**, where # is the allocation class to which you want the ISE set.

Example: **SET ALLCLASS 2** sets the allocation class to 2.

5. Type **SHOW ALLCLASS** to check the new allocation class.

6-12 Programming the DSSI Subsystem Using Console Commands

The system responds with the following display.

Parameter	Current	Default	Type	Radix
ALLCLASS	2	0	Byte	Dec B

PARAMS>

6. Type **WRITE** at the **PARAMS>** prompt. The system responds with:
Changes require controller initialization, ok? [Y/ (N)]
7. Type **Y** to save the new allocation class value.
8. Repeat Steps 3 through 8 for each ISE on the DSSI bus.

Configuring the DSSI Subsystem Using MDM Commands

This chapter discusses how to assign CSR addresses as a preparation for programming the KFQSA configuration table.

7.1 Determining CSR Addresses

Each module in a Q-bus based system must use a set of unique Q-bus addresses and interrupt vectors. One of these, generally the lowest of the set, is known as the CSR address.

7.1.1 Overview

The KFQSA emulates an SSP controller¹ for each connected ISE. Therefore, you must program the KFQSA with a correctly chosen CSR address for every ISE on the DSSI bus. Interrupt vectors for the KFQSA (and other SSP controllers) are programmed automatically by the operating system.

Unlike most other Q-bus controllers, KFQSA CSR addresses are not set with switches or jumpers. They are contained in nonvolatile memory on the KFQSA module in the form of a configuration table. The configuration table is programmed using an MDM program, as explained in Section 7.2.

NOTE

KFQSA modules installed in MicroVAX 3000 and 4000 series systems are more easily configured using the procedures given in Chapter 6.

¹ SSP controllers also include the RQDX3, KDA50, RRD50, RQC25, TQK50, and TQK70. All such ports are identical and are operated by the same PUDRIVER.

NOTE

To access the configuration table you must set the switches on the KFQSA to select one of the dedicated addresses shown in Table 4-2.

Before you program the configuration table you must first determine what the CSR addresses are going to be for all devices on the system. Calculating CSR addresses is a complex procedure because some devices are assigned floating addresses. Floating addresses vary depending on which modules are installed on the system.

Use an MDM utility called **IOADDRES** to determine what the CSR addresses and interrupt vectors should be for all devices on the system. This utility is supported in MDM Version 3.0, Release 125 or later. The next section describes how to use **IOADDRES**. You should already have a working knowledge of MDM. If you need detailed information on how to use MDM refer to the *MDM User's Guide (AA-FM7A-DM)*.

7.1.2 Using MDM to Determine CSR Addresses

1. Boot MDM.
2. Enter the correct date and time.
3. Select the command line mode (Option 2). The system issues a caution and instructs you to enter 1 for the menu mode or 2 to proceed with the command line mode.
4. Enter 2 and press **Return**. The system displays the MDM>> prompt.
5. Type the command **Run IOADDRES**. The system responds with:

```
Configuring utility for IOADDRES
```

The display prompts you to enter a number for each class of devices it supports. Table 7-1 shows the abbreviations for supported devices.

6. At each query, enter the number of devices from that class that are installed in the system. If no devices of that class are installed in the system, press **Return** (the default value of zero is entered)

After you have responded to all queries, the system displays a summary of the classes and the number of devices in each class. It then displays a table containing the following information.

- Device class and number of devices selected for that class
- CSR address and interrupt vector

- First available floating CSR address and vector

Table 7-1 Device Abbreviations Used with IOADDRESS

Device	Device Class	Device	Device Class
AAV11-DA	AAA	IDV11-A	IDA
AAV11-C	AAC	IDV11-B	IDB
ADQ32	AQA	IDV11-C	IDC
ADV11-C	ADC	IDV11-D	IDD
ADV11-DA	ADA	IEQ11	IEA
AXV11-C	AXA	KDA50	ZZZ
CXA16	DHA	KFQSA	ZZZ
CXF32	DHF	KMV1A	ZZY
DEQNA	XQA	KMV1B	ZZY
DESNA	CQA	KWV11-C	KWA
DFA01	ZZQ	KXJ11	KXA
DHF11	DHF	LNV11	LAA
DHV11	DH'	LNV21	LNA
DLV11	DL	LPV11	LPA
DMV11	DM	MIRA	MIA
DPV11	DPA	QCA	QCA
DRQ3B	QBA	RC25	ZZZ
DRQ11-C	DQA	RQDX _n	ZZZ
DRV11-J	DRB	RRD50	ZZZ
DRV11-W (DR11W mode)	ZZW	TQK50	ZZT
DRV11-W (DR11B mode)	ZZB	TSV05	TSA
DSV11	DSA	VCB01	VCA
DTC04	DTA	VCB02	VCB
DZQ11	ZZQ	VSV21	VVA
DZV11	ZZQ	Token Bus Adapter	ZQA
IAV11-A	IAA		
IAV11-B	IAB		
IBQ01	IBA		

- Print the information provided about the DSSI devices (or make a note of it) for programming the configuration table.
- Type **EXIT** and press .

Once the CSR values are determined for all modules in the system, the addresses for the DSSI devices must be programmed into the KFQSA configuration table using the procedure detailed in the next section. If any other modules in the system require reconfiguration, refer to the installation manual for that module, or to your system maintenance documentation for the configuration instructions.

7.2 Programming the KFQSA Configuration Table

Ordinarily, this procedure must be performed only when the board is installed for the first time or when a new storage element is added to the bus.

7.2.1 Programming a Blank or Unknown Configuration Table

Follow this procedure if the KFQSA is being installed for the first time or if for some reason, you cannot access a previously programmed configuration table. If adding a device to the DSSI bus, use the procedure detailed in Section 7.2.2.

1. Make sure that Switch 1 on the KFQSA module is in the ON position (Chapter 4).
2. Boot MDM.
3. Enter the correct time and date.
4. Enter the command line mode by selecting Option 2. The system prompts you with a caution. Enter 2 again. The MDM>> prompt appears on the screen indicating that you are now in the command line mode.
5. Type **SET AUTOCONFIG OFF**.
6. Type **SHOW BUS**. The display shows all devices ignored.
7. Find the NAKFA entry. It should show the CSR address you selected for the KFQSA (Chapter 4).
8. Type **CONNECT xxxxxx FILE_NAME NAKFA VECTOR nnn BR_LEVEL #**.

where:

xxxxxx is the CSR address assigned to the KFQSA

nnn is the interrupt vector

is the BR level

9. Type **SHOW BUS** again. This shows all devices ignored except the KFQSA.
10. Type **RESTART**.
11. Enter the menu mode.

12. At the main menu, select Option 2, Display System Configuration and Devices. The system displays the following:

The system is preparing for testing.

This may take several minutes.

Please Wait ...

The system will then display a line for each diagnostic it loads and configures. Then it will display the following:

The system is ready for testing.

Press the RETURN key to continue. >

13. Press **Return** to display the System and Configuration Devices Menu. This displays information about each device loaded and configured in the system.
14. Press **Return** again to return to the Main Menu.
15. Select Option 4, Display the Service Menu.
16. Select Option 3, Display the Device Menu.
17. Select KFQSAA, KFQSA Subsystem (option number will depend on your system configuration).
18. Select Option 4, Display the Device Utilities Menu.
19. Select Option 1, KFQSA Configuration Utility.

~~The system displays the KFQSA configuration table.~~

7-6 Configuring the DSSI Subsystem Using MDM Commands

KFQSA DSSI Node ID			
Entry #	CSR Address	DSSI Node ID	Model Number
Entry #0		0	
Entry #1	000000	0	0
Entry #2	000000	0	0
Entry #3	000000	0	0
Entry #4	000000	0	0
Entry #5	000000	0	0
Entry #6	000000	0	0
Entry #7	000000	0	0

Change KFQSA Configuration Table?
Valid response - [(yes) or no] :

NOTE

The configuration table may have been previously programmed for manufacturing testing or other purposes. In this case, it will contain information other than zeros for one or more entries. If this occurs, make sure that you clear any unused entries to zero while performing this procedure. Do so by following the steps in Section 7.2.3. If you cannot access the configuration table, check for correct DSSI termination.

20. Type **yes** and press **Return**.

The system responds:

Enter the number of the entry to change (0-7):

21. Type **0** and press **Return** to change the KFQSA DSSI node ID.

The system responds by displaying the entry #0 portion of the table.

	KFQSA DSSI Node ID	
Entry #0	-----	0

Change the KFQSA DSSI Node ID?
Valid response - [(yes) or no] :

22. Type **yes** and press **Return**.

The system responds with:

Enter a decimal value (0-7) for the KFQSA DSSI Node ID:

23. The KFQSA is normally set at DSSI node ID 7. Type **7** and press **Return**.

The system displays the configuration table with the newly entered information, along with the following:

Change another entry?
Valid response - yes or no:

24. Respond by typing **yes** and pressing **Return**. The system displays the following:

Enter the number of the entry to change (0-7):

25. Here, you select an entry number for one of the storage devices on your system DSSI bus. As an example, let us select Entry #1 by typing **1** and pressing **Return**.

The system displays the following:

	CSR Address	DSSI Node ID	Model Number
Entry #1	000000	0	0

Change CSR address or clear this entry ?
Valid response - [(yes) or no] :

7-8 Configuring the DSSI Subsystem Using MDM Commands

26. Respond by typing **yes**, and press **Return**.

The system displays the following:

Valid CSR addresses: Floating space: 760100 - 763776

Disk fixed address: 772150

Tape fixed address: 774500

Enter a 0 to clear this entry or a 18 bit octal number:

27. Type the address assigned to this device by IOADDRESS, and press **Return**.

The system responds:

Change DSSI node ID ?

Valid response - [(yes) or no] :

28. Type **yes**, and press **Return**.

The system responds with the following:

Enter a decimal number (0-7) for the DSSI Node ID:

29. Type in the DSSI node ID number you want to assign to that particular device followed by **Return**. Each entry must have a unique DSSI node ID assigned to it.

NOTE

Entries that are all zeros are ignored by the system. It is acceptable to assign DSSI node ID 0 to an entry with a valid CSR address, as long as it is only assigned to one device on the DSSI bus.

The system automatically adds the model number and displays the updated configuration table. It then displays the following query:

Change another entry?

Valid response - yes or no

30. Repeat Steps 21 through 26 until all devices on the DSSI bus have been assigned a CSR address, DSSI node ID, and model number. Any unused entries that have values assigned to them should be cleared to zero using the procedure outlined in Section 7.2.3.

31. Once you have entered all information into the configuration table, exit the table by typing **no** and pressing **Return** in response to the message:

```
Change another entry ?  
Valid response - [(yes) or no] :
```

The system displays one of the following messages:

```
This KFQSA is in CONFIGURE ONLY mode.  
Power down and place the board in NORMAL mode via KFQSA switches.
```

or

```
The manufacturing jumper is in.
```

32. Press **Return**. The system responds with:
- ```
KFQSA passed.
Press the RETURN key to return to the previous menu.
```
33. Press **Return**. The prompt puts you at the Utility Programs and Tests menu.
34. Exit MDM by pressing **Break**.
35. Power down the system and remove the KFQSA from its backplane slot.
36. Put Switch 1 in the OFF position.
- If the message in Step 28 indicated that the manufacturing jumper is in, remove it before replacing the board. Refer to Chapter 2 for information on removing this jumper.
37. Replace the KFQSA board in its backplane slot.
38. Power up the system.
39. Reboot MDM and repeat Steps 1 through 16. Read the CSR table to make sure that everything you entered is correct.
40. If everything is as it should be, respond **no** to the query:
- ```
Change KFQSA Configuration Table?  
Valid response - [(yes) or no] :
```
- Then, press **Return**. If further modifications are required, repeat Steps 17 through 27 to make the desired modifications.
41. Repeat Steps 28 through 32.

7.2.2 Adding a Device to the Configuration Table

NOTE

Adding a device to the KFQSA configuration table may change the CSR address of other devices in the Q-bus floating address space.

1. Leave Switch 1 on the KFQSA module in the OFF position.
2. Perform Steps 2 through 17 of Section 7.2.1. In this case, the configuration table will already contain information that was previously entered. As an example, let us assume there was a KFQSA with two ISEs already on the system and you are adding another ISE. The configuration table would then be displayed with information already in Entries 0, 1, and 2.

KFQSA DSSI Node ID			
Entry #	CSR Address	DSSI Node ID	Model Number
Entry #0		7	
Entry #1	772150	0	21
Entry #2	760334	1	21
Entry #3	000000	0	0
Entry #4	000000	0	0
Entry #5	000000	0	0
Entry #6	000000	0	0
Entry #7	000000	0	0

Change KFQSA Configuration Table ?
Valid Response - [(yes) or no] :

3. Type **yes**, and press **Return**. The system displays the following:

Enter the number of the entry to change (0-7):

4. Select the next available entry. For our example we select Entry #3 by typing **3** and pressing **Return**. The system displays the following:

	CSR Address	DSSI Node ID	Model Number
Entry #3	000000	0	0

Change CSR address or clear this entry ?
Valid response - [(yes) or no] :

- Respond by typing **yes** and pressing **Return**.

The system displays the following:

Valid CSR addresses: Floating space: 760100 - 763776
Disk fixed address: 772150
Tape fixed address: 774500
Enter a 0 to clear this entry or a 18 bit octal number:

- Type the address assigned to this device by IOADDRESS, and press **Return**. For purposes of our example, let us say the CSR address is supposed to be 760444.

The system responds with the following:

Change DSSI node ID ?
Valid response - [(yes) or no] :

- Type **yes**, and press **Return**.

The system responds with the following:

Enter a decimal number (0-7) for the DSSI Node ID:

- Type in the DSSI node ID number you want to assign to that particular device followed by **Return**. Each entry must have a unique DSSI node ID assigned to it. For purposes of our example, let us assign DSSI node ID 2.

The system automatically enters the model number and displays the updated configuration table as follows:

7-12 Configuring the DSSI Subsystem Using MDM Commands

KFQSA DSSI Node ID			
Entry #0	7		
	CSR Address	DSSI Node ID	Model Number
Entry #1	772150	0	21
Entry #2	760334	1	21
Entry #3	760444	2	21
Entry #4	000000	0	0
Entry #5	000000	0	0
Entry #6	000000	0	0
Entry #7	000000	0	0

Change another entry ?
Valid response - [(yes) or no] :

9. If you are adding more devices, repeat Steps 3 through 8 for each device you are adding. Follow the procedure outlined in Section 7.2.3 to clear any unused entries.

When you have filled in the table for each device on the DSSI bus, type **no** and press **Return**. The system responds with:

KFQSAA passed.
Press the RETURN key to return to the previous menu.

10. Press **Return**. The prompt returns to the Utility Programs and Tests menu.
11. Exit MDM by pressing **Break**.
12. Power down the system. Then power it back up to write the changes you made to the configuration table.

7.2.3 Removing a Device from the Configuration Table

NOTE

Removing a device to the KFQSA configuration table may change the CSR address of other devices in the Q-bus floating address space.

When taking a DSSI device off the bus, you need to clear the information in the configuration table for that device. As an example, let us remove the ISE we added in Section 7.2.2.

1. Leave Switch 1 on the KFQSA in the OFF position.
2. Perform Steps 2 through 17 of Section 7.2.1. The system displays the following:

KFQSA DSSI Node ID			
Entry #0	7		
	CSR Address	DSSI Node ID	Model Number
Entry #1	77 150	0	21
Entry #2	760334	1	21
Entry #3	760444	2	21
Entry #4	000000	0	0
Entry #5	000000	0	0
Entry #6	000000	0	0
Entry #7	000000	0	0

Change KFQSA Configuration Table ?
Valid response - [(yes) or no] :

3. Type **yes**, and press **Return**. The system displays the following.

Enter the number of the entry to change (0-7):
4. Select the entry number for the device you are removing. For our example, we will select Entry #3 by typing 3 and pressing **Return**. The system displays the following:

7-14 Configuring the DSSI Subsystem Using MDM Commands

	CSR Address	DSSI Node ID	Model Number
Entry #3	760444	2	21

Change CSR address or clear this entry ?
Valid response - [(yes) or no] :

5. Respond by typing **yes** and pressing **Return**.

The system displays the following:

Valid CSR addresses: Floating space 760100 - 763776
Disk fixed address: 772150
Tape fixed address: 774500
Enter a 0 to clear this entry or a 18 bit octal number:

6. Type **0** and press **Return**. The system responds with the message:

The DSSI Node ID and Model Number are automatically zeroed.
Press RETURN to continue

When you press **Return**, the configuration table is displayed with the CSR address, DSSI node ID, and model number reset to zeros for the selected entry number, as follows:

KFQSA DSSI Node ID			
Entry #0		7	
	CSR Address	DSSI Node ID	Model Number
Entry #1	772150	0	21
Entry #2	760334	1	21
Entry #3	000000	0	0
Entry #4	000000	0	0
Entry #5	000000	0	0
Entry #6	000000	0	0
Entry #7	000000	0	0

Change another entry ?
Valid Response - [(yes) or no] :

7. Repeat the procedure for each device you want to delete from the table. When you have finished editing the table, type **no** and press **Return**. The system responds with:

KFQSAA passed.
Press the RETURN key to return to the previous menu.
8. Press **Return**. The prompt returns to the Utility Programs and Tests menu.
9. Exit MDM by pressing **Break**.
10. Power down the system. Then power it back up to write the changes you made to the configuration table.

7.3 Programming the KFQSA for a DSSI VAXcluster Configuration

This section describes how to program the KFQSA modules in a DSSI VAXcluster.

NOTE

In a DSSI VAXcluster environment, a three-system configuration's maximum length of cable(s) (measured from the two end KFQSAs) is 82 feet in a computer room environment and 65 feet in an office environment.

The maximum number of enclosures in a DSSI VAXcluster configuration is 5. For example, two VAX or MicroVAX systems and three expansion enclosures.

Figure 7-1 is a diagram of a typical two-system DSSI VAXcluster application, which will be used as an example during this procedure.

NOTE

The DSSI cable(s) should be connected between the two systems, and power to both systems should be turned on before programming.

Perform the following procedure on System A:

1. Determine the correct CSR address for each device and module in the system by performing the steps outlined in Section 7.1.2. Make sure to include all devices residing in the system and all ISEs connected to the DSSI bus.

Figure 7-1 Two-System DSSI VAXcluster Configuration

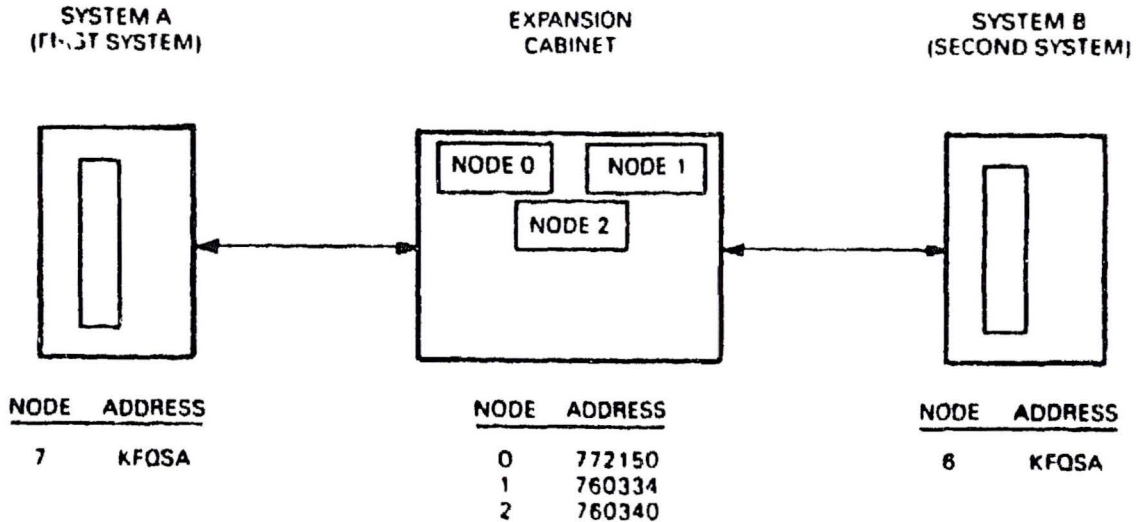

SHR 0034 84

2. Program the KFQSA configuration table to add the CSR addresses, DSSI node ID, and model number for the ISEs, as detailed in Section 7.2.

NOTE

Make sure all DSSI node IDs programmed into the configuration table are sequential and in increasing order. Do not skip any numbers.

3. Reprogram any modules whose CSR addresses were bumped as a result of including the ISEs.
4. Assign a DSSI node ID of 7 to the KFQSA in System A.
5. Repeat the procedure in Steps 1 through 3 for System B. Assign a DSSI node ID of 6 to the KFQSA in this system.

NOTE

Make sure that the ISEs have been assigned the same DSSI node IDs in both KFQSA configuration tables.

CAUTION

Make sure that the device name of each ISE is identical on both nodes. Failure to do so can result in a partitioned cluster, and consequently data corruption.

6. Replace any necessary DSSI unit ID plugs in the Operator Control Panel for each ISE to make them match the DSSI node IDs assigned to the ISEs for a DSSI VAXcluster configuration.
7. Boot one node and note the device names reported by VMS software.
8. Shut down the node and boot the other one. Note the device names to ascertain that both systems see the same set of device names.

7.4 Setting the ISE Allocation Class

This section describes how to change the ISE allocation class. In a DSSI VAXcluster configuration, you must assign the same nonzero allocation class to all host systems and to all ISEs on the DSSI bus.

NOTE

DSSI ISEs are shipped with the allocation class set to zero.

Change the allocation class by using the following procedure. This procedure only needs to be performed from one of the host systems.

1. Determine the correct allocation class for the ISEs according to the rules on clustering.

NOTE

In a DSSI VAXcluster configuration, the same allocation class must be assigned to all systems and to all connected ISEs. This allocation class must be different from that of other systems or HSC in a cluster.

2. Set Switch 1 on the KFQSA to OFF.
3. Enter MDM and select the menu mode. The screen displays the following:

MAIN MENU

- 1 - Test the system
- 2 - Display System Configuration and Devices
- 3 - Display the System Utilities Menu
- 4 - Display the Service Menu
- 5 - Display the Connect/Ignore Menu
- 6 - Select single device tests

7-18 Configuring the DSSI Subsystem Using MDM Commands

Type the number; then press the RETURN key.

4. Select the Service Menu (#4). The screen displays:

Service Menu

CAUTION: This menu is intended for use by qualified service personnel only. Misuse of the commands could destroy data.

- 1 - Set test and message parameters
- 2 - Exercise system continuously
- 3 - Display the device menu
- 4 - Enter command line mode

Type the number; then press the RETURN key, or type 0 and press the RETURN key to return to the Main Menu.

5. Select the device menu (#3). In this example, there are other device diagnostics loaded. The screen displays:

MAIN
SERVICE
DEVICE

This menu lets you select a device for testing.

- 1 CPUA - MicroVAX/rtVAX CPU
- 2 MEMA - MicroVAX memory system
- 3 RQDXA - Winchester diskette controller
- 4 TKXXA - TK50/TK70 controller
- 5 KFQSA - KFQSA subsystem

6. Select the device-specific KFQSA subsystem (#5) menu. The screen displays:

DEVICE MENU
KFQSA - KFQSA subsystem menu

Testing is Enabled

- 1 - Enable/Disable testing for device
- 2 - Perform all functional tests
- 3 - Perform the exerciser test
- 4 - Display the device utilities menu

7. Select #4, the device utilities menu.

The KFQSA DEVICE UTILITY MENU displays utilities and special subsystem tests:

MAIN MENU
 SERVICE MENU
 DEVICE MENU
 KFQSAA - KFQSA SUBSYSTEM MENU
 UTILITY PROGRAM AND TESTS MENU

Utility selections are:

- 1 - KFQSA Configuration Utility
- 2 - DSSI Device Data Erase Utility
- 3 - Select Device Resident Programs
- 4 - KFQSA Information Gathering Service
- 5 - Customize Diagnostic Functionality Utility

8. Select #3, the Device Resident Programs menu. The system displays:

RUNNING A UTILITY SERVICE TEST

To halt the test at any time and return to the previous menu,
 type CTRL-C by holding down the CTRL key and pressing the C key.

KFQSAB started.

KFQSAB pass 1 test number 3 started.

Copyright 1988 Digital Equipment Corporation

Completed.

EXIT	DRVEXR	DRVTST
HISTORY	ERASE	PARAMS
DIRECT	VERIFY	DKUTIL

Please choose a local program or press <RETURN> to continue.

NOTE

The Select Device Resident Programs Utility works only when Switch 1 on the KFQSA module is OFF.

9. Type **PARAMS**, and press Return.
10. At the **PARAMS>** prompt, type **SHOW ALLCLASS** to check the current allocation class.

The system responds with the following display.

Parameter	Current	Default	Type	Radix
-----	-----	-----	-----	-----
ALLCLASS	1	0	Byte	Dec B

PARAMS>

11. Type **SET ALLCLASS #**, where # is the allocation class you want to set the ISE to.

7-20 Configuring the DSSI Subsystem Using MDM Commands

Example: SET ALLCLASS 2 sets the allocation class to 2.

12. Type **SHOW ALLCLASS** to check the new allocation class.

The system responds with the following display.

Parameter	Current	Default	Type	Radix
ALLCLASS	2	0	Byte	Dec B

PARAMS>

13. Type **WRITE**. The system responds with:

Changes require controller initialization, ok? [Y/ (N)]

14. Type **Y** to save the new allocation class value.
15. Repeat the preceding procedure for each ISE on the DSSI bus.

8

Diagnos^tics

This chapter describes the diagnostics for testing the KFQSA module and the connected DSSI ISEs.

8.1 Power-On Self-Test Diagnostics

The KFQSA module has a power-on self-test (POST) that performs a comprehensive set of logic tests whenever power is applied to the module, or when the host issues a Q-bus BUS INIT. POST tests about 95 percent of the KFQSA module's logic and executes in less than ten seconds. It executes whether or not any other DSSI devices are connected to the KFQSA module.

The KFQSA module has one green and five red LEDs mounted on the edge of the board (Figure 8-1). When power is applied, all five LEDs light. The red LEDs go out as POST routines are executed successfully. After the successful completion of all POST routines only the green LED remains lit.

NOTE

In some cases, the red LEDs go out so quickly that you may think they never came on. If the green LED is on when you look at the module after applying power, POST ran successfully.

Figure 8-1 KFQSA MODULE LEDS Location

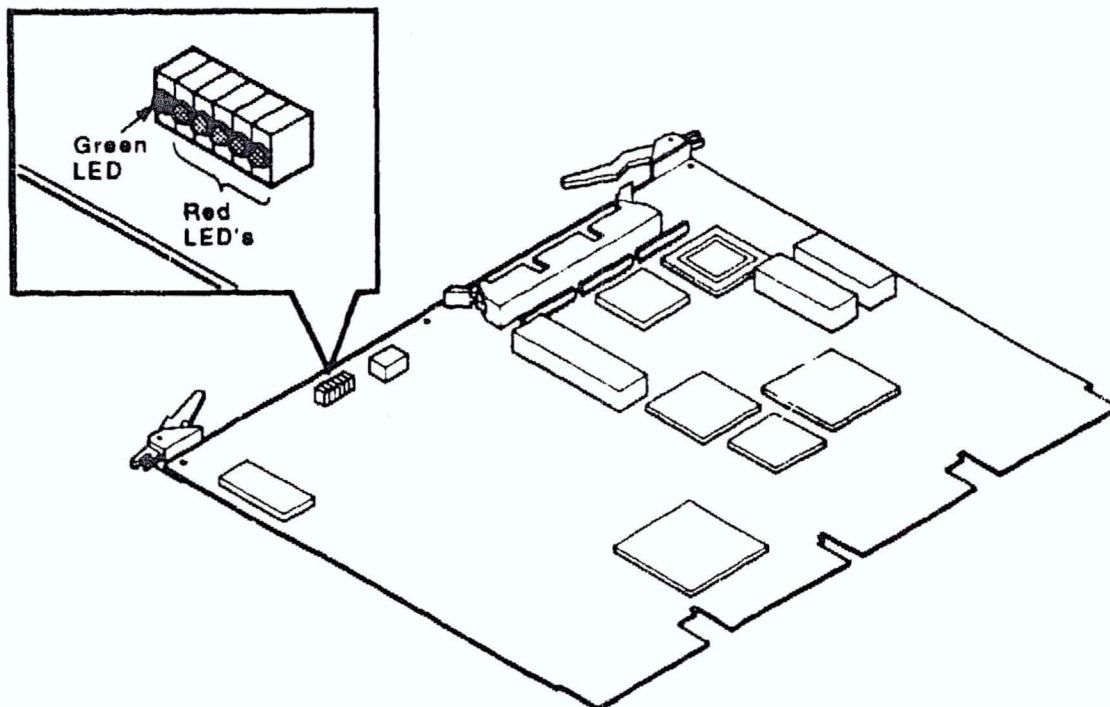

LJ-01723-T10

8.2 LED Error Codes

The two types of errors detected by POST are fatal errors and nonfatal errors. Fatal errors cause the adapter to abort service and wait for reinitialization. Nonfatal errors are recoverable.

A POST failure also causes an error code to be sent to the SA registers. When the error is fatal, the microprocessors are forced into an infinite loop sequence that can only be broken by receiving an INIT from the host.

If a nonfatal error is detected, the green LED remains lit and the red LEDs display an error code for approximately ten seconds. Table 8-1 shows the POST LED nonfatal error codes.

If a fatal error is detected, the green LED goes out and a sequence of red LEDs remains lit. Table 8-2 shows the POST LED fatal error codes.

Table 8-1 POST LED Nonfatal Error Codes

Green LED	Red LEDs					Meaning
	4	3	2	1	0	
•	○	○	○	○	•	At least one (but not all) CSR address parity error ¹
•	○	○	○	•	○	At least one (but not all) discrete port error in the QMI chip ¹
•	○	○	•	○	○	Successful retry during a RAM test ¹
•	○	•	○	○	○	Watchdog timer non-fatal error ¹
•	○	○	○	○	○	POST passed.

○ = LED off, • = LED on

¹The nonfatal error code is displayed for ten seconds (minimum).

8-4 Diagnostics

Table 8-2 POST LED Fatal Error Codes

Green LED	Red LEDs					Meaning
	4	3	2	1	0	
•	•	•	•	•	•	Never got started or 8096 CPU error
○	○	○	○	○	○	8096 setup error
○	○	○	○	○	•	CSRD chip test error
○	○	○	○	•	○	QMI Chip test error
○	○	○	○	•	•	Fatal configuration table error ¹
○	○	○	•	○	○	8096 EPROM test error
○	○	○	•	○	•	8096 DPRAM test error (low byte)
○	○	○	•	•	○	8096 DPRAM test error (high byte)
○	○	○	•	•	•	68000's CPU test error
○	○	•	○	○	○	68000's 10 usec BERR timer test error
○	○	•	○	○	•	68000's EPROM test error
○	○	•	○	•	○	68000's local RAM test error (low byte)
○	○	•	○	•	•	68000's local RAM test error (high byte)
○	○	•	•	○	○	68000 interrupt vector test error
○	○	•	•	○	•	DSSI timer test error
○	○	•	•	•	○	FIFO chip test error
○	○	•	•	•	•	Buffer RAM parity test error
○	•	○	○	○	○	Buffer RAM test error (first 64K, bits 0...3)
○	•	○	○	○	•	Buffer RAM test error (first 64K, bits 4...7)
○	•	○	○	•	○	Buffer RAM test error (first 64K, bits 8...11)
○	•	○	○	•	•	Buffer RAM test error (first 64K, bits 12...15)
○	•	○	•	○	○	Buffer RAM test error (second 64K, bits 0...3)
○	•	○	•	○	•	Buffer RAM test error (second 64K, bits 4...7)
○	•	○	•	•	○	Buffer RAM test error (second 64K, bits 8...11)
○	•	○	•	•	•	Buffer RAM test error (second 64K, bits 12...15)

¹It is possible to solve fatal configuration table errors without replacing the KFQSA module. Set Switch 1 to the ON position, boot, and attempt to reconfigure the table.

Table 8-2 (Continued) POST LED Fatal Error Codes

Green LED	Red LEDs					Meaning
	4	3	2	1	0	
○	●	●	○	○	○	SII chip test error
○	●	●	○	○	●	68000's DPRAM test error (low byte)
○	●	●	○	●	○	68000's DPRAM test error (high byte)
○	●	●	○	●	●	Microprocessor interrupt test error
○	●	●	●	○	○	68000 bus error
○	●	●	●	○	●	Unexpected interrupt (68000 side)
○	●	●	●	●	○	8096 setup complete error
○	●	●	●	●	●	Parity error during BRAM test

○ = LED off, ● = LED on

8.3 Using MDM to Run NAKFA Diagnostics

NAKFA is a KFQSA functional diagnostic that is executed using the MicroVAX Diagnostic Monitor (MDM) utility. The MDM utility scans for individual devices on the bus, and loads one image of NAKFA for each device it sees on the DSSI bus. Like all MDM diagnostics, NAKFA is menu driven.

NOTE

This section is written for users with a working knowledge of the MDM utility.

8.3.1 Loading NAKFA

There are several ways to load and execute MDM diagnostics. This section describes one way in which only the device being tested is selected. This allows more time for KFQSA module or DSSI device troubleshooting.

1. Load MDM.

(For example: >>>B DUA1.)

The system displays the following:

8-6 Diagnostics

MicroVAX Diagnostic Monitor initializing.....Please wait

MicroVAX Diagnostic Monitor - Version 3.0

CONFIDENTIAL DIAGNOSTIC SOFTWARE
PROPERTY OF
DIGITAL EQUIPMENT CORPORATION

Use Authorized Only Pursuant to a Valid Right-to-use License

Copyright (c) 1986, 1988
Digital Equipment Corporation

The current date and time is: 12-JAN-1989 13:30

Press the RETURN key to continue,
or enter the new date and time; then press the RETURN key.

[DD-MMM-YYYY HH:MM]:

The current date and time is: 12-JAN-1989 13:30

2. Enter the correct date and time, then press **Return**.

The following text is displayed on the screen:

Do you want to use menu mode or command line mode?

- 1 - menu mode
- 2 - command line mode

Type the number; then press the RETURN key.

3. Select command line mode.
4. At the prompt, type the following:

MDM>>SHOW BUS

This shows you information about devices that can be tested. For example:

Autoconfigure set ON

Filename	CSR	VECTOR	BR_LEVEL	STATUS
NAKAA	160000	000	0	CONNECTED
NAMSA	160002	000	0	CONNECTED
.				
.				
.				
NAKFA	160334	300	4	CONNECTED

The bus display defaults are *Autoconfigure set ON* and *STATUS CONNECTED*. These defaults mean that the diagnostics are loaded automatically when the system is configured.

5. At the prompt, type the following:

```
MDM>>SET AUTOCONFIGURATION OFF
```

This command reverses the status of diagnostics to *IGNORED*. This means that the diagnostics are not loaded when the system is configured.

6. At the prompt, type the following:

```
MDM>>connect 160334 file_name NAKFA vector 300 br_level 4
```

7. At the prompt, type the following:

```
MDM>>SHOW BUS
```

The system displays new configuration and status. For example:

```
Autoconfigure set OFF
```

Filename	CSR	VECTOR	BR_LEVEL	STATUS
NAKAA	160000	000	0	IGNORED
NAMSA	160002	000	0	IGNORED
.				
.				
.				
NAKFA	160334	300	4	CONNECTED

8. At the prompt, type the following:

```
MDM>>CONFIGURE
```

9. At the prompt, type the following:

```
MDM>>SHOW CONFIGURATION BRIEF
```

The following list of enabled diagnostics is displayed:

```
1 NO Ld KAA Disabled
2 NO Ld MSA Disabled
.
.
.
5 KFQSAA - KFQSA subsystem
MDM>>
```

8.3.2 Testing the KFQSA Subsystem Using NAKFA in Menu Mode

This section explains how to use the MDM utility to access the MDM device menu, NAKFA's KFQSA subsystem menu, and NAKFA's KFQSA utility tests and program menu.

Use the following procedure to access the KFQSA device menu:

1. Boot MDM. Select menu mode in response to menu mode or command line mode query.

The following is displayed on the screen:

MAIN MENU

- 1 - Test the system
- 2 - Display System Configuration and Devices
- 3 - Display the System Utilities Menu
- 4 - Display the Service Menu
- 5 - Display the Connect/Ignore Menu
- 6 - Select single device tests

Type the number, then press the RETURN key.

2. Select the service menu.

The following is displayed on the screen:

Service Menu

CAUTION: This menu is intended for use by qualified service personnel only. Misuse of the commands could destroy data.

- 1 - Set test and message parameters
- 2 - Exercise system continuously
- 3 - Display the device menu
- 4 - Enter command line mode

Type the number; then press the RETURN key, or type 0 and press the RETURN key to return to the Main Menu.

3. Select the device menu. In this example, other device diagnostics are loaded. The following text is displayed on the screen:

MAIN
SERVICE
DEVICE

This menu lets you select a device for testing.

- 1 CPUA - MicroVAX/rtVAX CPU
- 2 MEMA - MicroVAX memory system
- 3 RQDXA - Winchester diskette controller
- 4 TKXXA - TK50/TK70 controller
- 5 KFQSAA - KFQSA subsystem

4. Select KFQSAA, KFQSA subsystem menu (#5).

The following text is displayed on the screen:

```

DEVICE MENU
KFQSAA - KFQSA subsystem menu

Testing is Enabled

1 - Enable/Disable testing for device
2 - Perform all functional tests
3 - Perform the exerciser test
4 - Display the device utilities menu

```

5. Select the device utilities menu.

The KFQSA device utility menu displays the following utilities and special subsystem tests:

```

MAIN MENU
SERVICE MENU
DEVICE MENU
KFQSAA - KFQSA SUBSYSTEM MENU
UTILITY PROGRAM AND TESTS MENU

Utility selections are:

1 - KFQSA Configuration Utility
2 - DSSI Device Data Erase Utility
3 - Select Device Resident Programs
4 - KFQSA Information Gathering Service
5 - Customize Diagnostic Functionality Utility

```

The KFQSA configuration utility is used to program the KFQSA configuration table, as described in Chapter 6.

You can use this utility to install DSSI add-on devices if at least one DSSI device is attached and has a valid address in the configuration table, and the KFQSA module is in its normal operating mode (that is, Switch 1 on the KFQSA module is set to the OFF position). However, if the configuration table is corrupted, you must set Switch 1 to the ON position, reboot the KFQSA module, and reconfigure EEROM using this utility.

8-10 Diagnostics

The select device resident programs utility is used to select the following device-resident programs:

- EXIT
- HISTRY
- DIRECT
- DRVEXR
- ERASE
- DRVTST
- PARAMS
- VERIFY
- DKUTIL

NOTE

The select device resident programs utility works only when Switch 1 on the KFQSA module is set to OFF.

Refer to your ISE manual or system documentation for further information on using local programs to test the ISE.

CAUTION

The remainder of the utilities in the Utility Program and Tests Menu are for Digital Services use only. Do *not* attempt to use any of these unless you are properly trained. Erasure or corruption of data may result from incorrect use.

8.3.3 Halting Test Execution

To halt NAKFA, type **Ctrl/C**. NAKFA stops running, and the MDM utility reports any errors that were detected during testing.

8.4 Using Console Commands for Testing DSSI Devices

For systems having console command capability, the ISEs on the DSSI bus may be tested by using a simple command.

At the console prompt (>>>) type:

```
>>> SET HOST/DUP/UQSSP/DISK # xxxxxx
```

where:

- # is the DSSI node ID of the ISE you want to test.
- xxxxxx is the name of the ISE local program you want to access. The following local programs are available.
 - EXIT
 - HISTRY
 - DIRECT
 - DRVEXR
 - ERASE
 - DRVTST
 - PARAMS
 - VERIFY
 - DKUTIL

Refer to your ISE manual or system documentation for further information on using local programs to test the ISE.

KFQSA Troubleshooting

The tools used to diagnose the KFQSA module and connected ISEs are:

- POST, power-on self test, described in Section 8.1.
- NAKFA, KFQSA module's functional diagnostic, described in Section 8.3 or the SET HOST/DUP console command described in Section 8.4.

Generally, KFQSA module failures fall into one of two categories:

- The system fails to boot because of a KFQSA module problem.
- The system boots, but the KFQSA module fails.

In the case of a boot failure, verify the installation again using the procedures outlined in Chapter 5. Then verify the configuration using the procedures outlined in Chapter 6 or Chapter 7. Most boot problems are caused by incorrectly setting up the device configuration or addressing.

If the system boots but the KFQSA module fails, reapply power to cause POST to run, and check for the presence of a LED error code.

Always perform a visual inspection of the KFQSA module and all connected DSSI devices before troubleshooting. Some KFQSA module problems that can be solved by visual inspection are listed in Table 9-1.

Table 9-1 KFQSA Troubleshooting Symptom Analysis

Symptom	Possible Resolution
Green LED on external DSSI terminator is extinguished.	Blown fuse on KFQSA module or dc power problem on DSSI bus. Includes cables and KFQSA and DSSI ISE controller modules.
Continually blowing fuses on the KFQSA module.	Incorrectly plugged or cables that are not DSSI cables.
Cannot access Configuration Table.	Incorrect termination on the KFQSA module. Make sure KFQSA is terminated either through on-board SIP terminators or external DSSI terminators.
Error Code 03 on KFQSA LEDs (red LEDs 0 and 1 are lit)	Fatal configuration table error. Use procedures in Chapter 6 or Chapter 7 to reprogram the configuration table.
With Switch 1 in the OFF position, MDM displays IP WRITE FAILURE.	A NAKFA image has been corrupted. Reload NAKFA.
Excessive VMS error logs.	Nonexistent or powered-off device on the DSSI bus.
No DSSI devices seen by operating system.	Attempting to boot DSSI devices when Switch 1 is set to ON. Set Switch 1 to OFF.
Cannot boot MDM with KFQSA on the bus.	Conflicting boot addresses. Use KFQSA module switches to choose a dedicated address.
Undeterminable fatal or nonfatal errors.	Incorrect bus termination, incorrect DSSI cable connections, or improper grounding. Make sure the DSSI bus is terminated and the terminator LED is lit to avoid incorrect bus termination.
NAKFA or VMS error logs display NO VC.	Incorrect device connection on the DSSI bus. The KFQSA module must have at least one DSSI device that can be addressed, connected and available on the bus. Also, the configuration table must accurately reflect the devices present, both CSR and DSSI node ID.

Index

A

Allocation class, 6-11, 7-17

B

BA123 enclosure, 1-10
 Installation procedure, 5-9
BA213 enclosure, 1-7
 Installation procedure, 5-6
BA23 enclosure, 1-12
 Installation procedure, 5-14
BA440 enclosure
 Installation procedure, 5-2
BA440 Enclosure, 1-5
Bulkhead cover, 1-8, 5-3, 5-6

C

Configuration table, 4-3, 7-1
 DSSI VAXcluster, 7-15
 DSSI VAXcluster systems, 6-8
 Programming using console
 commands, 6-3
 Programming using MDM, 7-4
Configuration worksheet, 3-1
Console commands, 6-1
 CONFIGURE, 6-2, 6-8
 EXIT, 6-3
 HELP, 6-2, 6-9
 SET HOST/DUP, 8-11
 SHOW QBUS, 6-5, 6-8
 SHOW UQSSP, 6-6, 6-7
CSR address, 4-1, 6-1, 7-1
 Dedicated KFQSA address, 4-3
 Floating address, 6-2, 7-2
 MSCP or TMSCP generic address,
 4-4

D

Diagnostics, 8-1
DSSI, 1-1
DSSI node ID, 6-4, 6-5, 6-10, 6-11,
 7-7, 7-11, 7-16, 8-11
DSSI VAXcluster, 1-14
DSSI VAXcluster configuration, 6-7,
 7-15

G

Gap filler assembly, 5-3, 5-7

I

IOADDRESS, 7-2
IP WRITE FAILURE, 9-2
ISE, 1-1
ISE local programs, 8-10, 8-11

J

Jumper, 2-3

K

KFQSA fuse, 9-2
KFQSA switches, 4-1

M

MDM
 Command line mode, 8-6
 CONFIGURE, 8-7
 Menu mode, 8-8
 NAKFA, 8-5

MDM (cont'd)

SET AUTOCONFIGURATION
OFF, 8-7

SHOW BUS, 8-6

SHOW CONFIGURATION
BRIEF, 8-7

Multihost restrictions, 5-18

N

NAKFA, 7-4, 9-1

NO VC, 9-2

O

Operator control panel, 6-10, 7-17

Option kits, 2-2

P

PARAMS, 7-19

SET ALLCLASS, 6-11, 7-19

SHOW ALLCLASS, 6-11, 7-19

WRITE, 6-12, 7-20

POST, 8-1, 9-1

Fatal error codes, 8-4

Fatal errors, 8-2

Nonfatal error codes, 8-2

Nonfatal errors, 8-2

POST LED error codes, 8-2

POST LEDs, 8-1

S

SET HOST/DUP, 9-1

SET HOST/IQSSP/MAINT
/SERVICE, 6-3

SSP controller, 6-1, 7-1

T

Terminator, 2-2, 5-13, 5-16

Troubleshooting, 9-1